

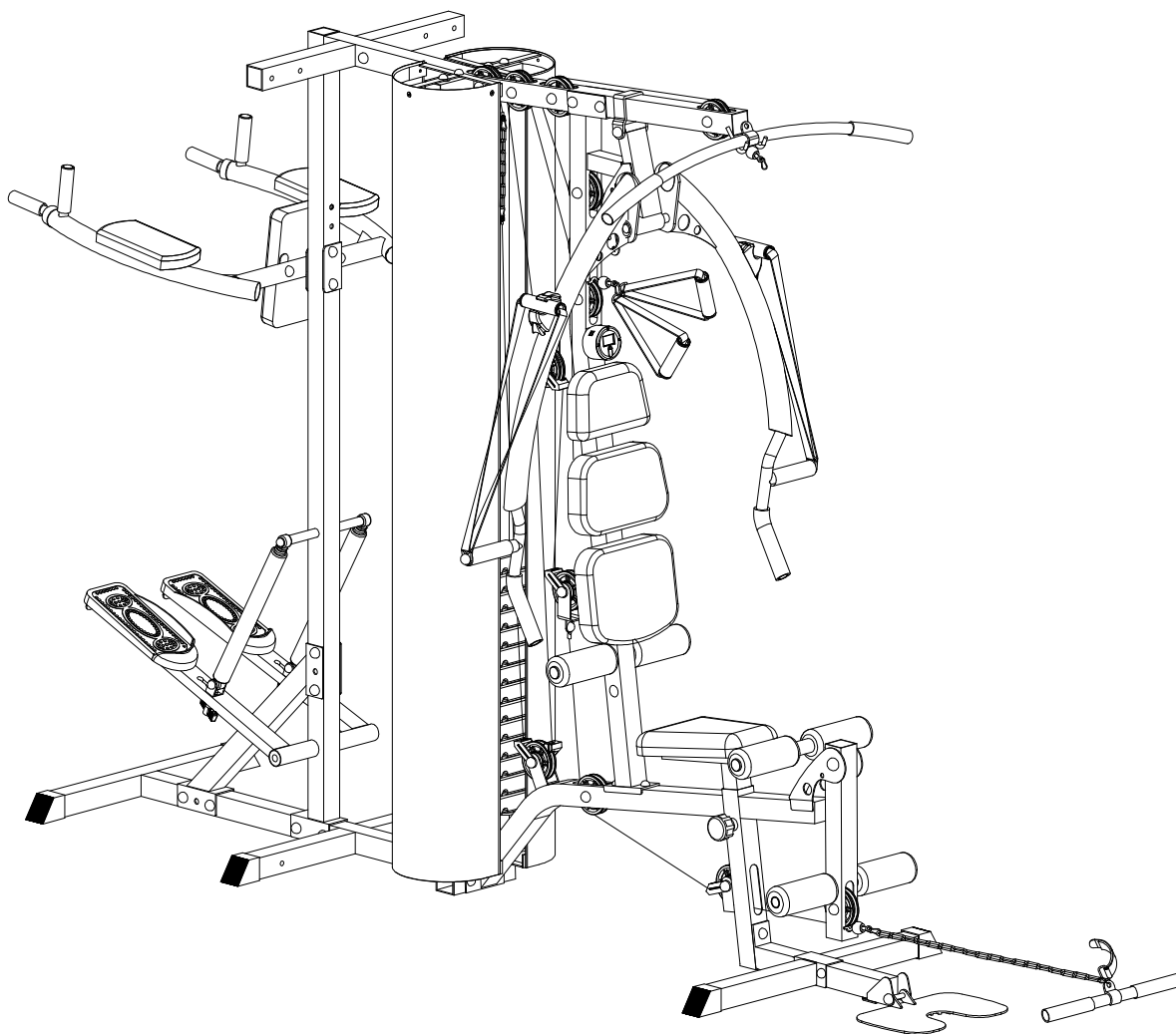

User manual-EN

IN 333 Home Gym inSPORTline Phantom



Part list:







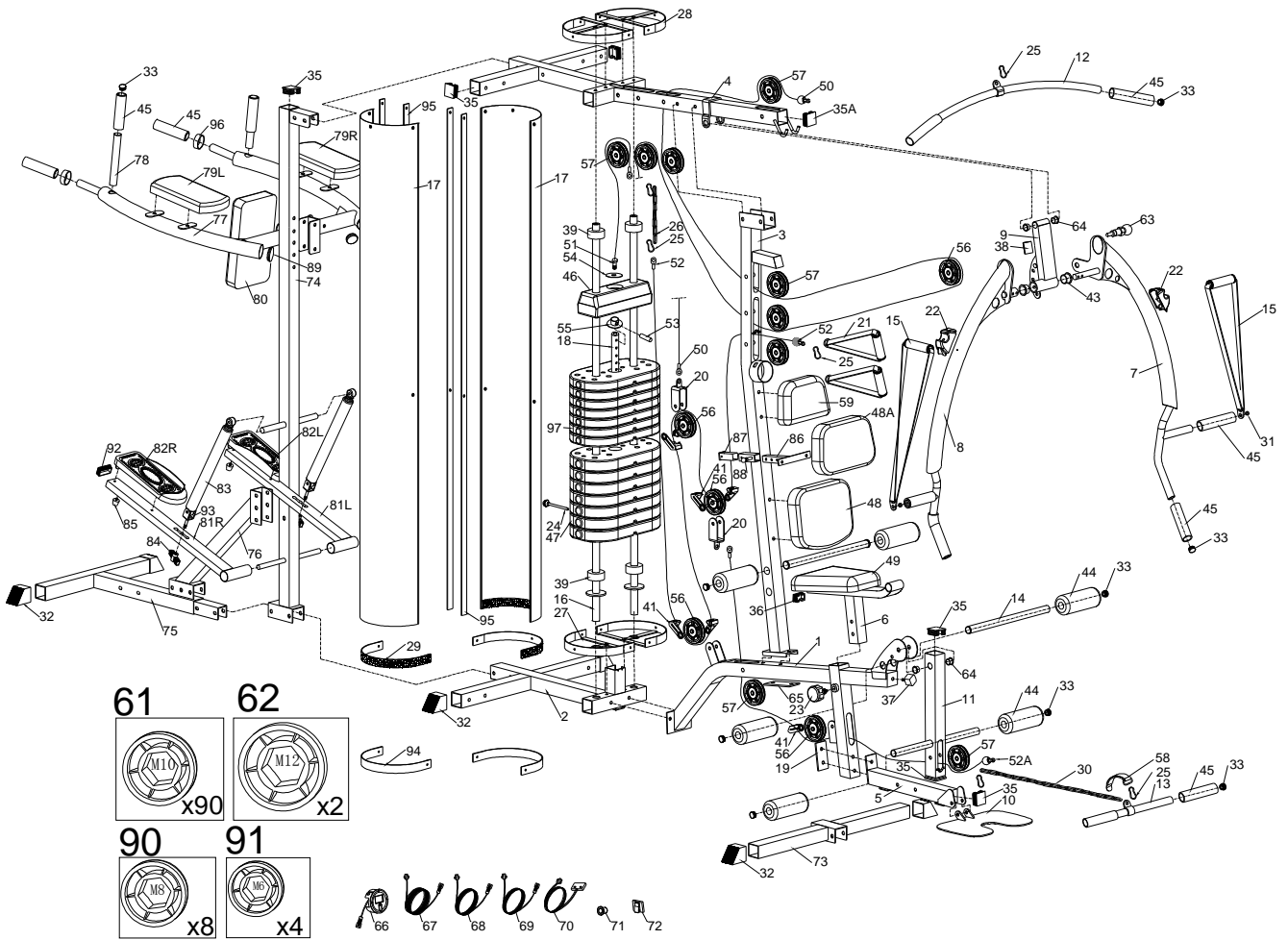



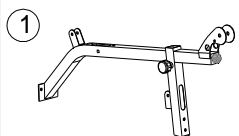
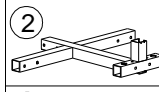
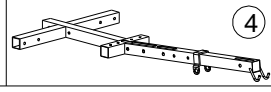



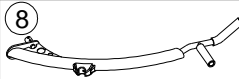

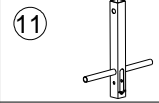
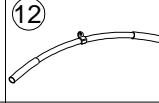

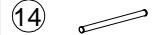

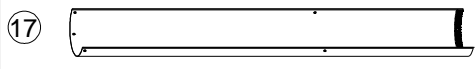

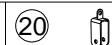









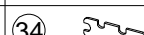



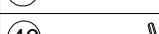
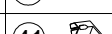

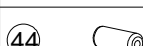







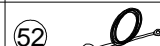
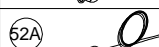

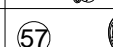
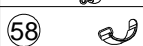

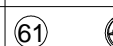





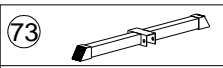

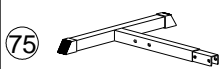

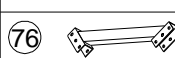

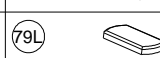

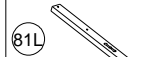
Part No.	Description	Q'ty	Part No.	Description	Q'ty
1	Main frame	1	64	Bushing D29*D21.5*D10.2	4
2	Middle floor frame	1	65	Fixing plate 50*120*3T	1
3	Front vertical support	1	66	Computer BC-80258	1
4	Top frame	1	67	Upper computer cable 720L	1
5	Front floor frame	1	68	Middle computer cable 550L	1
6	Seat support	1	69	Lower computer cable 400L	1
7	Left butterfly arm	1	70	Sensor cable 110L	1
8	Right butterfly arm	1	71	Plug D4*D12*13	2
9	Butterfly arm support	1	72	Nip for computer cable	3
10	Plate for foot	1	73	Front stabilizer	1
11	Leg extension tube	1	74	Rear vertical support	1
12	Upper pulling bar	1	75	Rear floor frame	1
13	Lower pulling bar	1	76	Rear incline support	1
14	Foam roller axle	2	77	Arm pad support	1
15	Belt (fabric) 40*650	2	78	Handlebar	2
16	Chrome guidance	2	79L	Left arm pad	1
17	Weight protector	2	79R	Right arm pad	1
18	Weight selector tube	1	80	Backrest	1
19	Fixing plate	1	81L	Left pedal support	1
20	Single pulley bracket	2	81R	Right pedal support	1
21	Belt (fabric) 240*130	2	82L	Left pedal	1
22	Cover 100.3*48*45	2	82R	Right pedal	1
23	Knob D56*M16*24*D8	1	83	Hydraulic cylinder	2
24	Ball pin	1	84	T-shape knob	1
25	Hook D8*80	6	85	Buffer D33*D44*41.5	2
26	Chain D4.8*18*34*248	1	86	Prop support	1
27	Lower weight protector support	2	87	Hollow cap 30*30*65L	1
28	Upper weight protector support	2	88	Knob D30*M16*1.5*29*D8	1
29	Ankle strap 496*30	2	89	Round cap D50*15	2
30	Chain D4.8*18*34*613	1	90	Screw cap D28*14 (M8)	8
31	Bushing D10*D12*5T	2	91	Screw cap D28*17 (M6)	4
32	Foot cap 50*50*76.5*4.5t	6	92	Square cap 50*50*18.5	2
33	Round cap D17*17.5	16	93	Fixing bracket for Hydraulic cylinder	2
34	Spanner	2	94	Curved plate	2
35	Square cap 50*50*18.5	5	95	Fixing tube	4
35A	Square cap 50*50*20L	1	96	Hollow cap D50.8*D26*D20L	2
36	Square cap 20*50*14	1	97	Mid weight plate	7

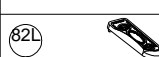
37	Buffer 35*35*25	1	100	Bolt M10*1.5*75L	14
38	Square buffer 42*42*5T	1	101	Flat washer D20*D11*2T	76
39	Round buffer D60*D26*26T	2	102	Nylon nut M10*1.5*10T	37
40	Allen spanner	1	103	Bolt M10*1.5*65L	18
41	Pulley guidance	7	104	Bolt M10*1.5*70L	4
42	Plastic ring of pulley	7	105	Screw M8*25L	2
43	Bushing D38*D35.2*32	2	106	Flat washer D24*D13.5*2.5T	2
44	Foam D23*D80*175L	6	107	Nylon nut M12*1.75*12T	1
45	Foam D23*D35*127L	12	108	Bolt M10*1.5*55L	1
46	Upper weight plate	1	109	Bolt M10*1.5*40L	2
47	Lower weight plate	7	110	Bolt M10*1.5*20L	2
48	Lower backrest	1	111	Bolt M12*1.75*85L	1
48A	Middle backrest	1	112	Bolt M10*1.5*60L	3
49	Seat	1	113	Bolt M10*1.5*95L	1
50	Cable (III) 3270L	1	114	Bolt M10*1.5*25L	10
51	Cable (IV) 1430L	1	115	Bolt M5*0.8*20L	6
52	Cable (II) 3040L	1	116	Flat washer D15*D5.2*1.0T	6
52A	Cable (I) 1535L	1	117	Bolt M6*1*20L	4
53	Upper weight selector pin	1	118	Flat washer D14*D6.5*0.8T	12
54	Flat washer D47.5*D13*3T	1	119	Nylon nut M6*1*6T	4
55	Upper weight selector socket	1	120	Bolt M8*1.25*15L	2
56	Raised pulley D90*D10*28.5	5	121	Flat washer D28*D8.5*3T	4
57	Flat pulley D90*D10*24	9	122	Flat washer D38*D8.5*3T	2
58	Ankle strap 295*95	1	123	Flat washer D19*D8.5*1.6T	8+4
59	Head pad	1	124	Bolt M6*1*35L	2
60	Bushing D18*D10*14.5	18	125	Bolt M8*1.25*20L	6
61	Screw cap D28*17*(M10)	90	126	Spring washer D15.4*D8.2*2T	4
62	Screw cap D30*17*(M12)	2	127	Bolt M6*1*40L	2
63	Spring pin	1	128	Bolt M8*65L	4

Exploded drawing



Checking list

	x1		x1		x1
			x1		
	x1		x1		x1
	x1		x1		x1
	x1		x1		x1
	x2		x2		x2
	x2				x1
	x1		x2		x2
	x1		x6		x1
	x2		x2		x1
	x2		x2		x2
	x2		x1		x4
	x1		x7		x7
	x6		x1		x7
	x1		x1		x1
	x1		x1		x1
	x1		x5		x9
	x1		x1		x90
	x2		x1		x1
	x1				x7
	x1		x1		
	x1				x1
	x1		x2		x1
	x1		x1		x1
	x1		x1		x2
	x2		x1		x8
	x4		x2		

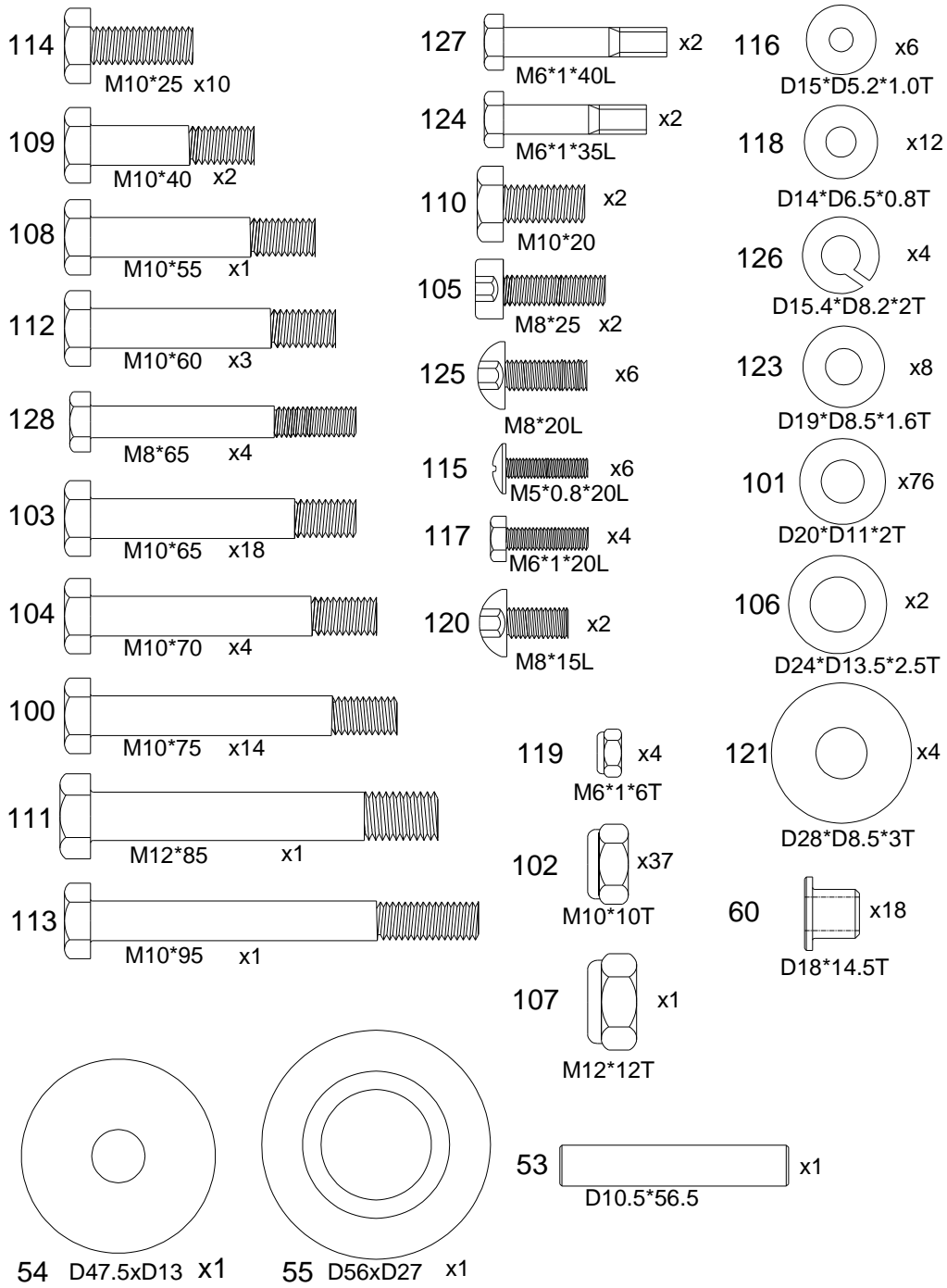

Assembly drawing

Step 1

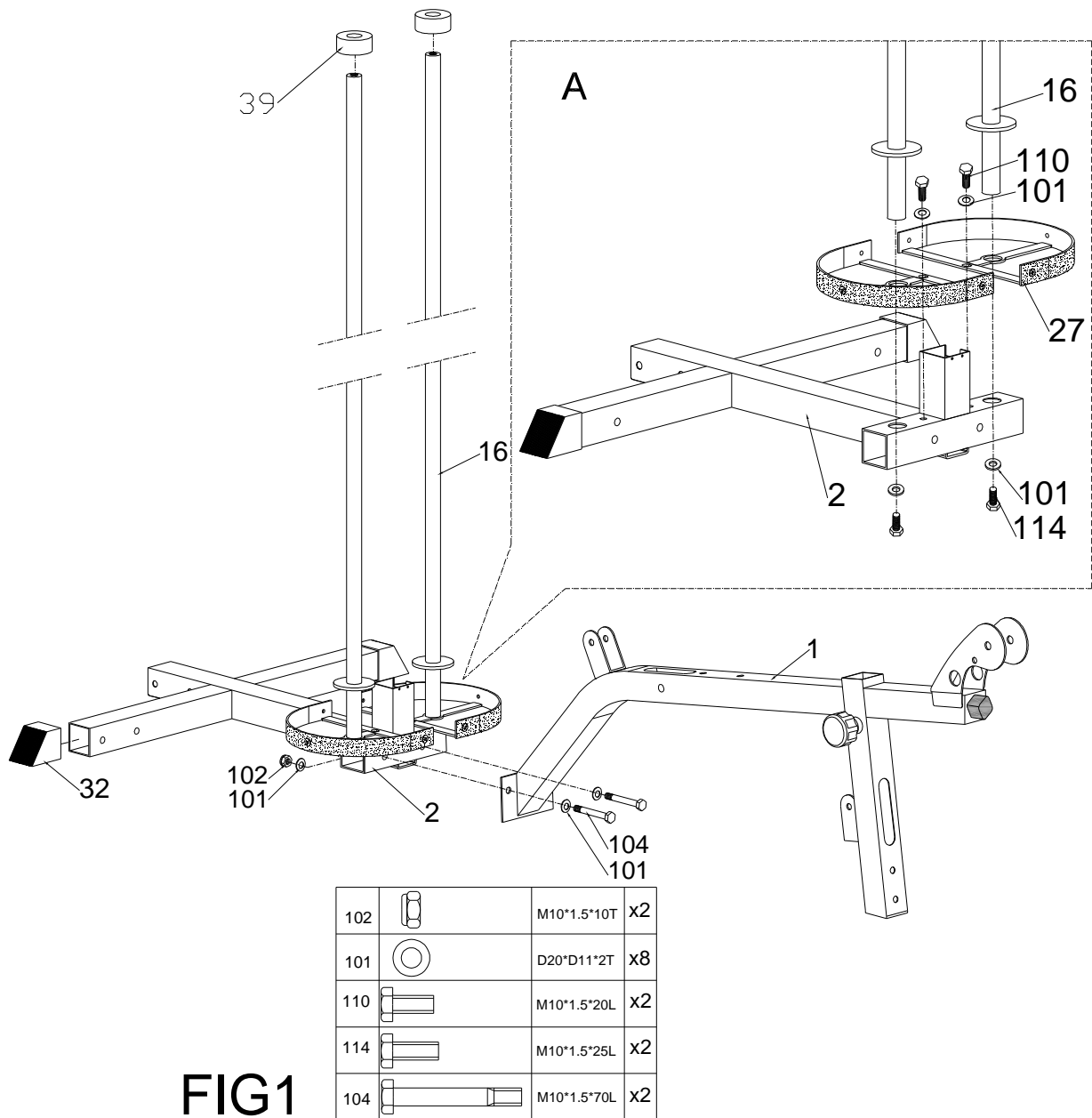

FIG1

- 1) Assemble the main frame (1) to the middle floor frame (2) by the flat washer (101), the nylon nut (102) and the bolt (104).
- 2) Assemble the lower weight protector (27) and the chrome guidance (16) to the middle floor frame (2) by the flat washer (101), the bolt (110) and the bolt (114) shown as fig. A.
- 3) Assemble the foot cap (32) to the middle floor frame (2).

Step 2

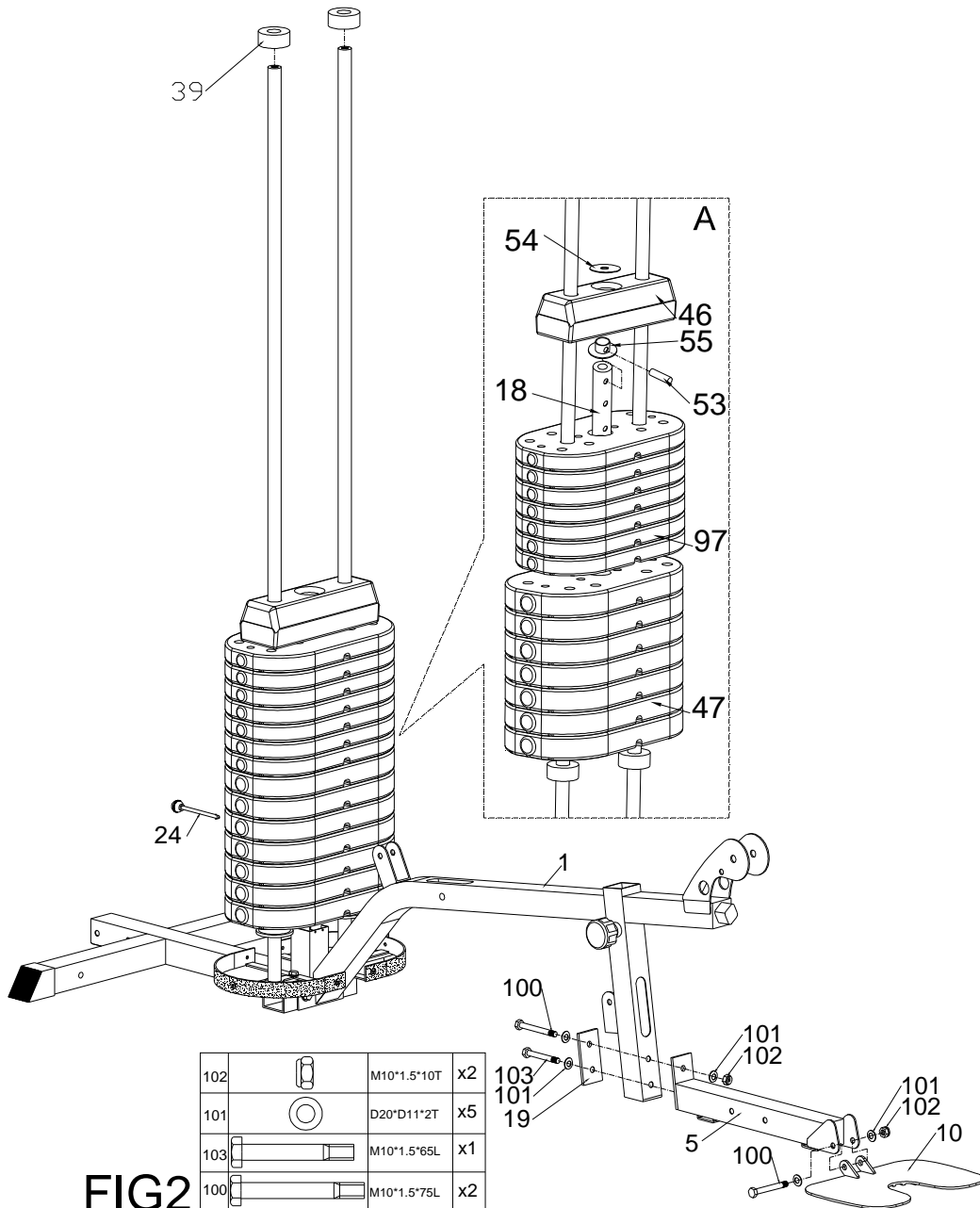

FIG2

- 1) Assemble the lower weight plate (47), the mid weight plate (97) and the upper weight plate (46) to the chrome guidance (16) shown as fig. A. Put the flat washer (54) on the hole of the upper weight plate (46).
- 2) Assemble the upper weight selector socket (55) to the weight selector tube (18) and fix the socket by the upper weight selector pin (53). Put the weight selector tube (18) in the hole of weight plates.
- 3) Assemble the front floor frame (5) to the main frame (1) by the fixing plate (19), the flat washer (101), the bolt (103) and the bolt (100) and the nylon nut (102).
- 4) Assemble the plate for foot (10) to the front floor frame (5) by the bolt (100), the flat washer (101) and the nylon nut (102).
- 5) Users could select the quantity of the weight plates by the ball pin (24).

Step 3

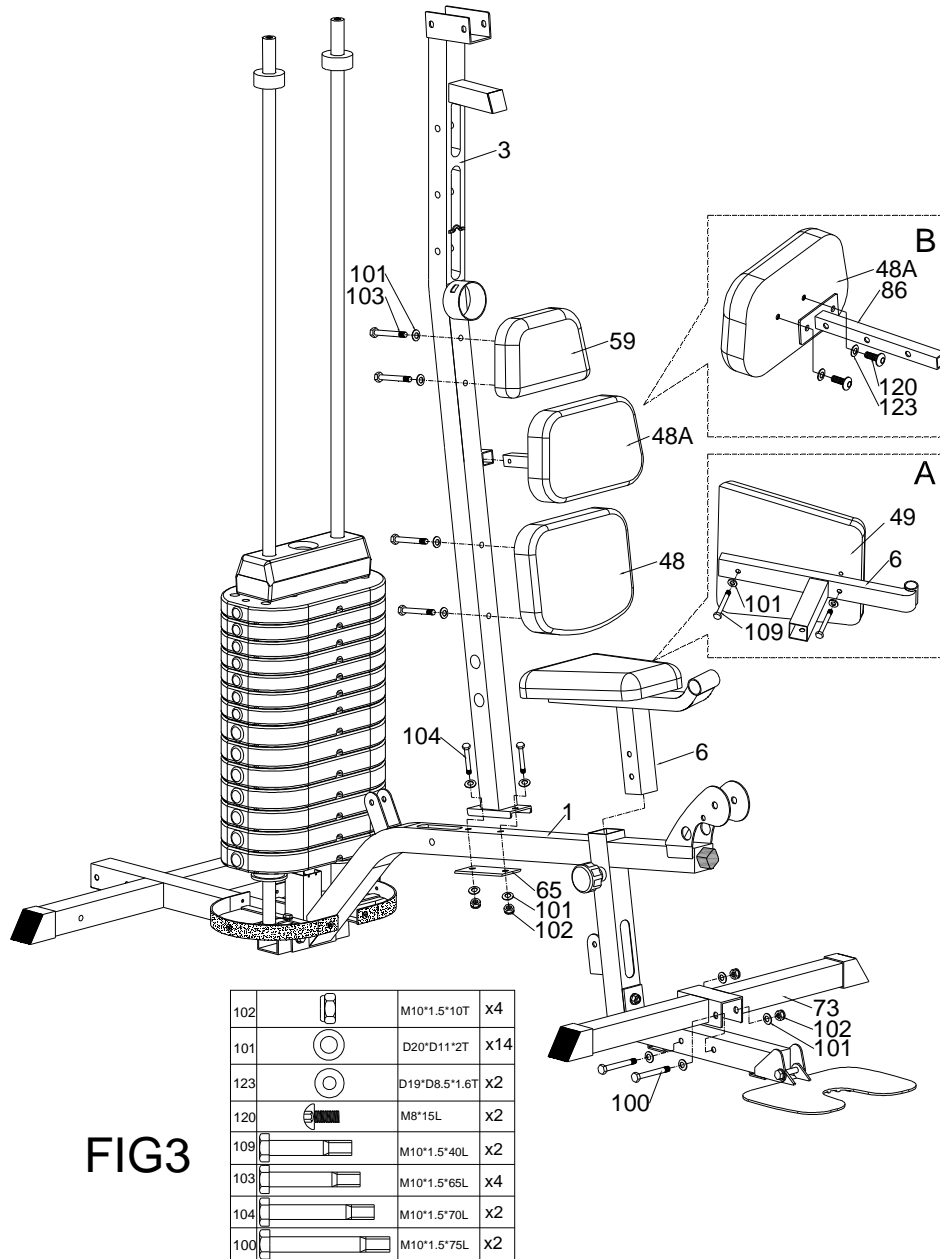

FIG3

- 1) Assemble the front vertical support (3) to the main frame (1) by the fixing plate (65), the flat washer (101), the bolt (104) and the nylon nut (102).
- 2) Assemble the seat (49) to the seat support (6) by the flat washer (101) and the bolt (109) shown as fig. A. Assemble the seat support (6) to the main frame (1).
- 3) Assemble the middle backrest (48A) to the prop support (86) by the bolt (120) and the flat washer (123) shown as fig. B.
- 4) Assemble the head pad (59), the middle backrest (48A) and the lower backrest (48) to the front vertical support (3) by the flat washer (101) and the bolt (103).
- 5) Assemble the front stabilizer (73) to the front floor frame (5) by the bolt (100), the flat washer (101) and the nylon nut (102).

Step 4

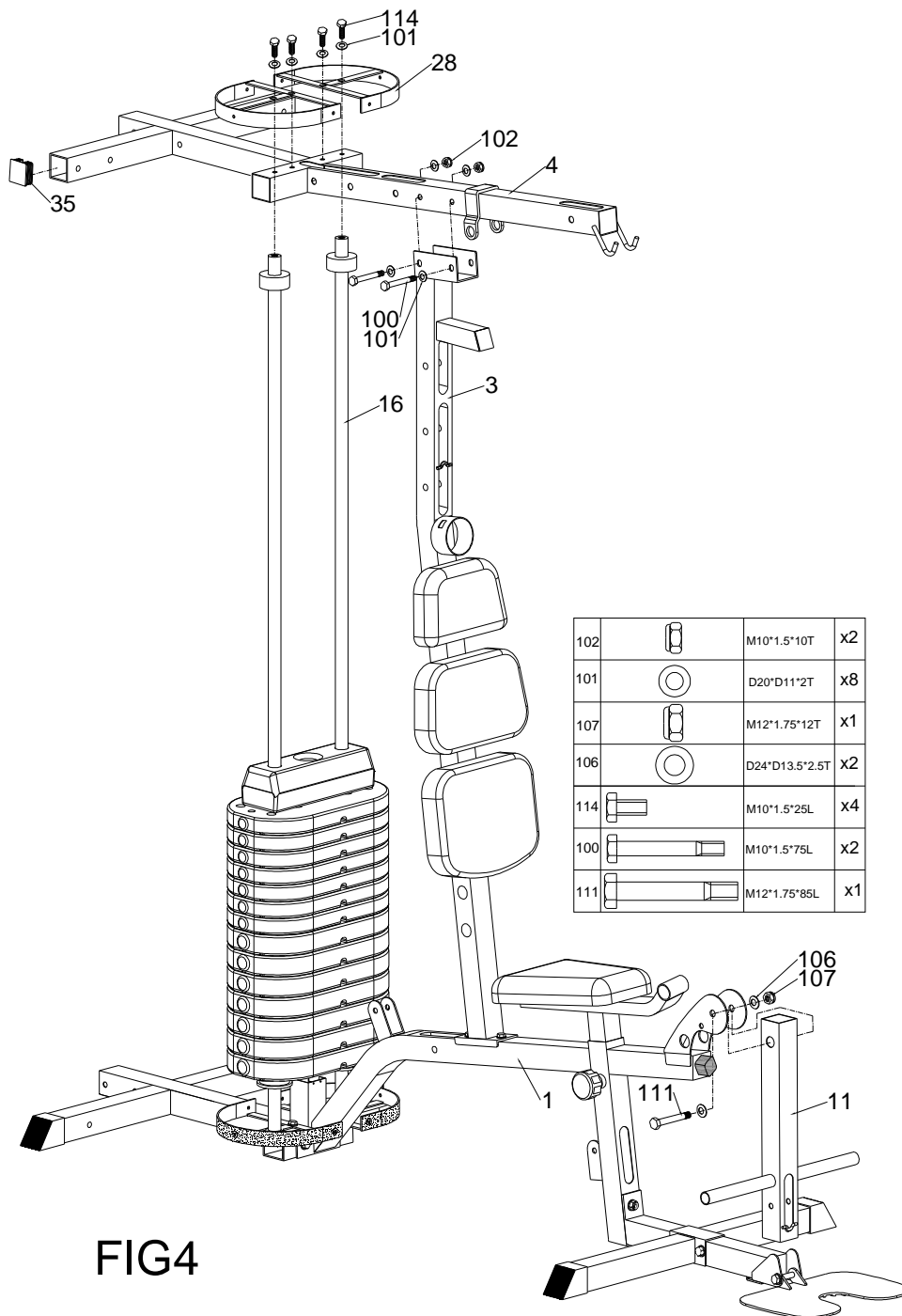

FIG4

- 1) Assemble the top frame (4) to the chrome guidance (16) and the front vertical support (3). Assemble the square cap (35) to the top frame (4).
- 2) Assemble the upper weight protector support (28) to the top frame.
- 3) Fix the upper weight protector support (28), the top frame (4) and the chrome guidance (16) by the flat washer (101) and the bolt (114).
- 4) Fix the top frame (4) to the front vertical support (3) by the bolt (100), the flat washer (101) and the nylon nut (102).
- 5) Assemble the leg extension tube (11) to the main frame (1) by the flat washer (106), the nylon nut (107) and the bolt (111).

Step 5

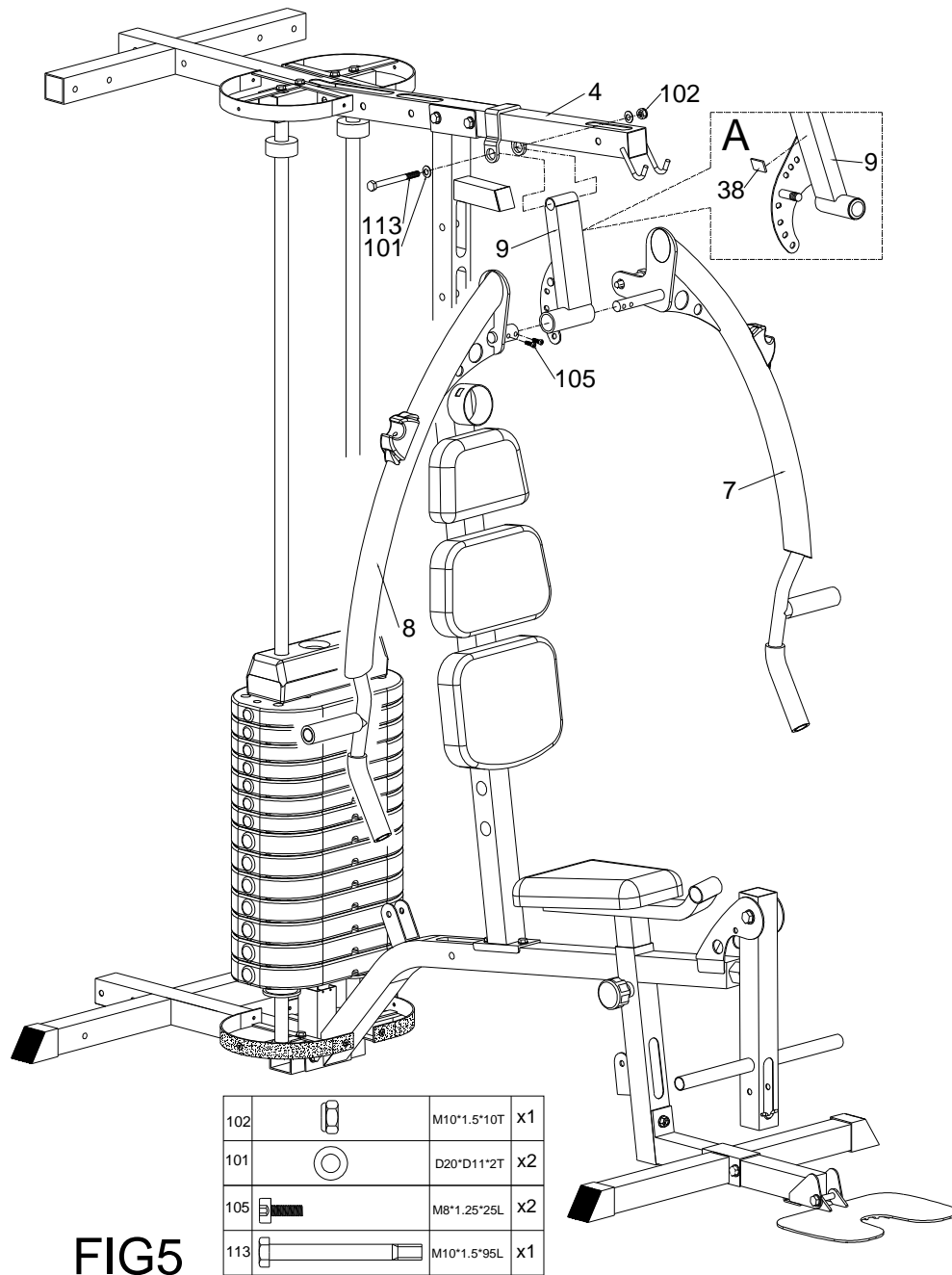
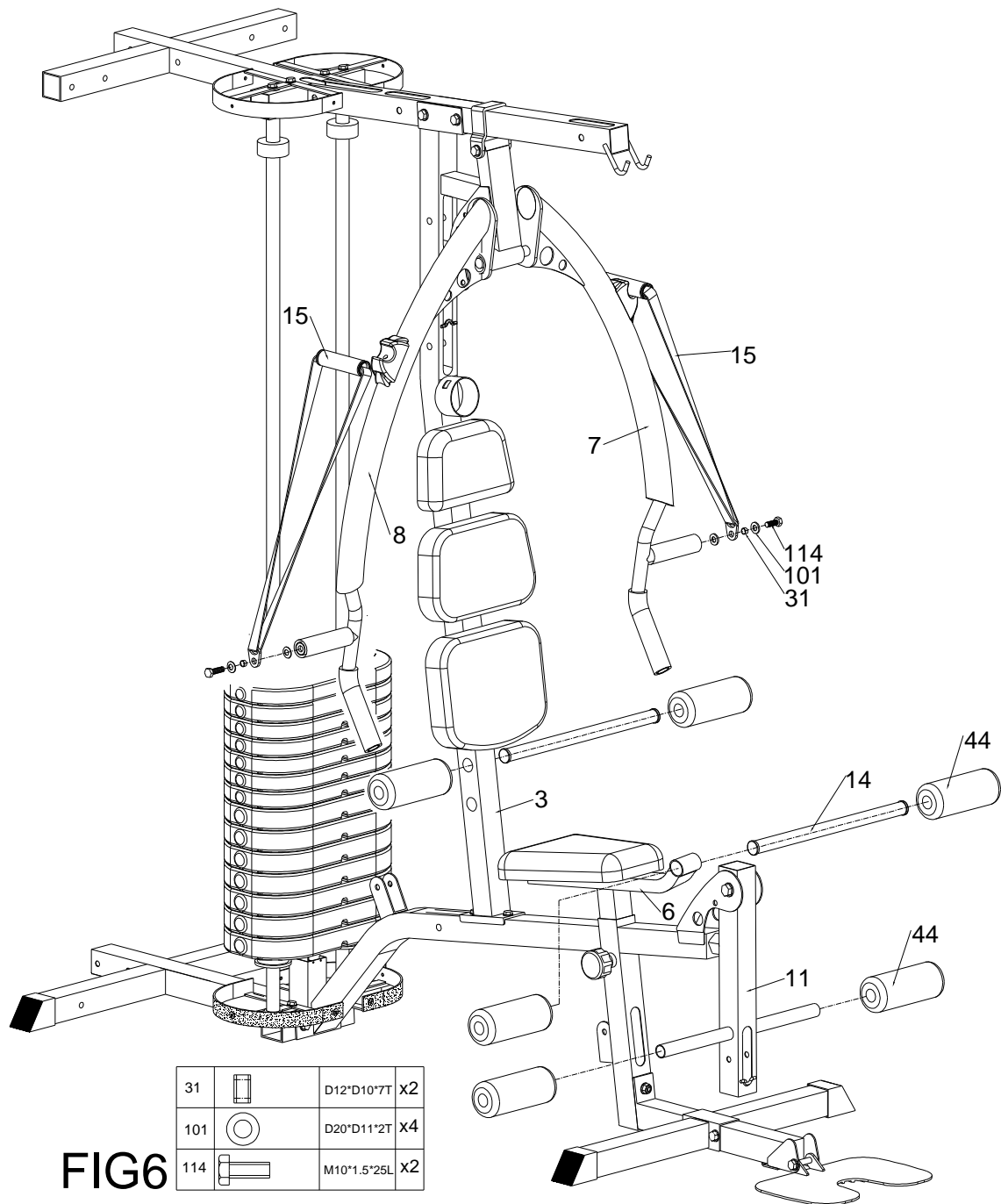

FIG5

- 1) Assemble the butterfly arm support (9) to the top frame (4) by the flat washer (101), the nylon nut (102) and the bolt (113).
- 2) Assemble the left butterfly arm (7) and the right butterfly arm (8) to the butterfly arm support (9) by the screw (105).
- 3) Attach the square buffer (38) on the butterfly arm support (9) shown as fig A.

Step 6



- 1) Assemble the belt (fabric) (15) to the left butterfly arm (7) and the right butterfly arm (8) by the bushing (31), the flat washer (101) and the bolt (114).
- 2) Assemble the foam roller axle (14) to the front vertical support (3), the seat support (6) and the leg extension tube (11). Assemble the foam (44) to the foam roller axle (14).

Step 7

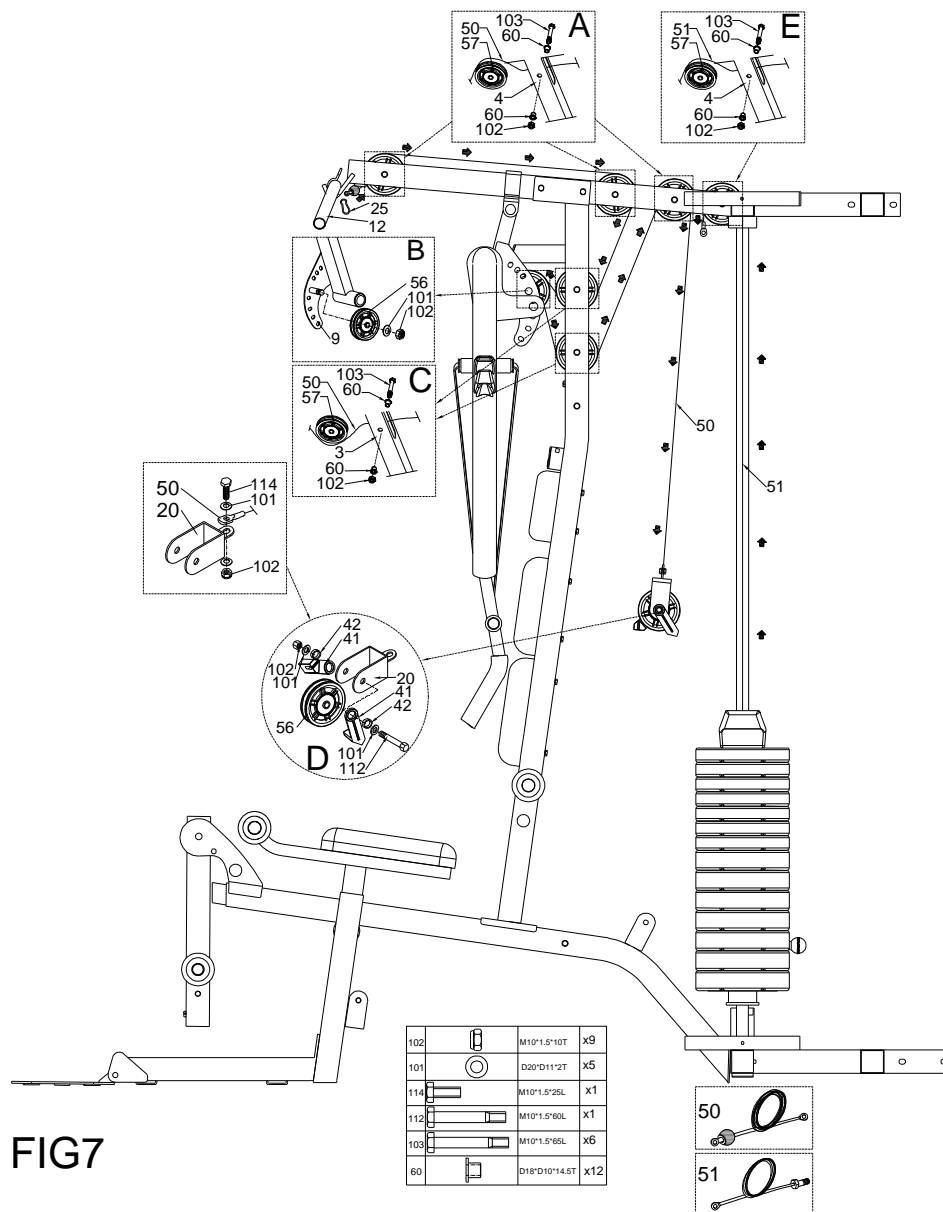

FIG7

- 1) Assemble the flat pulley (57) to the top frame (4) by the bushing (60), the bolt (103) and the nylon nut (102) shown as fig. A.
- 2) Assemble the raised pulley (56) to the butterfly arm support (9) by the flat washer (101) and the nylon nut (102) shown as fig. B.
- 3) Assemble the flat pulley (57) to the front vertical support (3) by the bushing (60), the bolt (103) and the nylon nut (102) shown as fig. C.
- 4) Assemble the raised pulley (56) to the single pulley bracket (20) by the pulley guidance (41), the plastic ring of pulley (42), the flat washer (101) and the nylon nut (102) shown as fig. D.
- 5) Assemble the cable (50) shown as the arrows. Assemble the end with loop of the cable (50) to the single pulley bracket (20) by the flat washer (101), the nylon nut (102) and the bolt (114).
- 6) Assemble the upper pulling bar (12) to the top frame (4) by the hook (25).
- 7) Assemble the flat pulley (57) to the top frame (4) by the bushing (60), the bolt (103) and the nylon nut (102) shown as fig. E. Assemble the cable (51) shown as the arrows.

Step 8

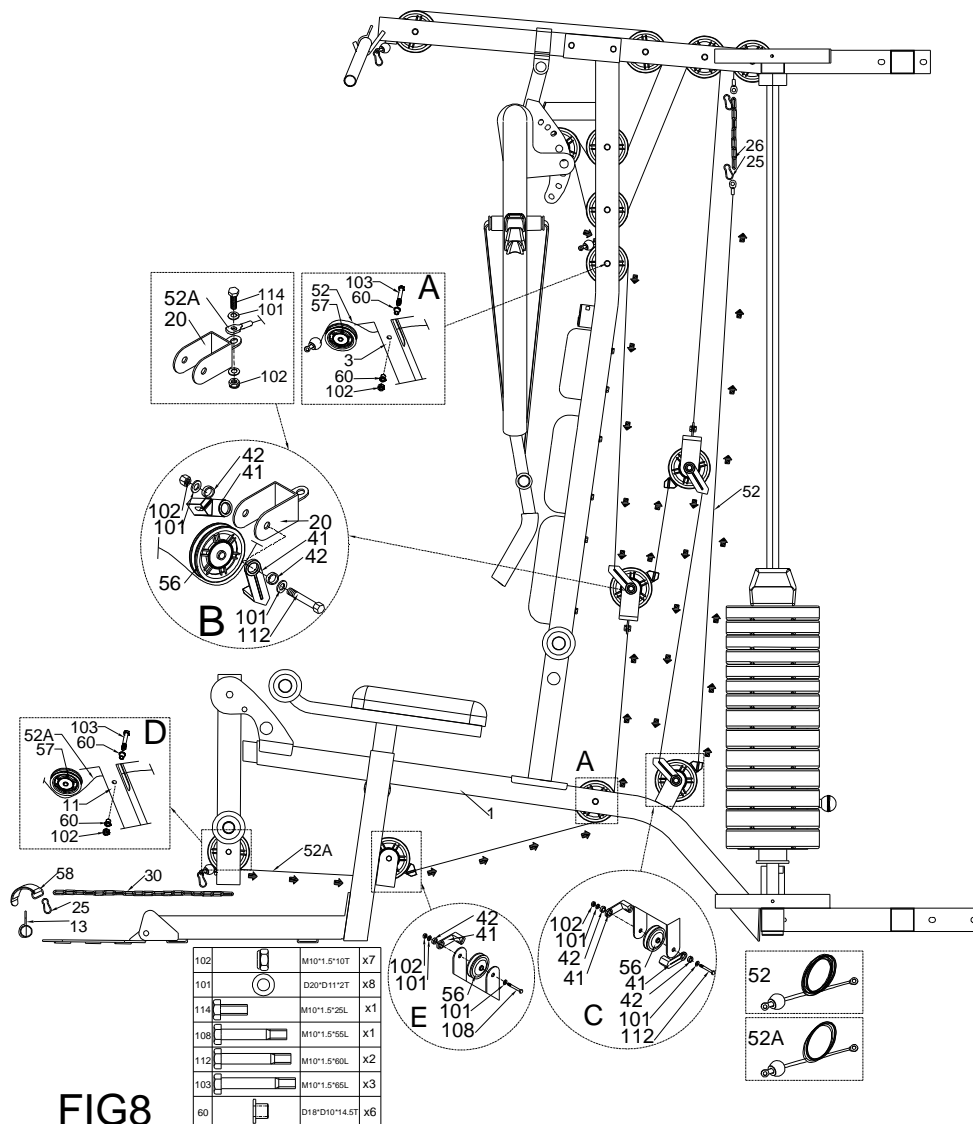

FIG8

- 1) Assemble the flat pulley (57) to the front vertical support (3) by the bushing (60), the bolt (103) and the nylon nut (102) shown as fig. A.
- 2) Assemble the raised pulley (56) to the single pulley bracket (20) by the pulley guidance (41), the plastic ring of pulley (42), the flat washer (101), the bolt (112) and the nylon nut (102) shown as fig. B.
- 3) Assemble the raised pulley (56) to the main frame (1) by the pulley guidance (41), the plastic ring of pulley (42), the flat washer (101), the bolt (112) and the nylon nut (102) shown as fig. C.
- 4) Assemble the cable (52) shown as arrows. Connect the cable (52) with the cable (51) by the hook (25) and the chain (26).
- 5) Assemble the flat pulley (57) to the leg extension tube (11) by the bushing (60), the bolt (103) and the nylon nut (102) shown as fig. D.
- 6) Assemble the raised pulley (56) to the main frame (1) by the pulley guidance (41), the plastic ring of pulley (42), the flat washer (101), the bolt (108) and the nylon nut (102) shown as fig. E.
- 7) Assemble the cable (52A) shown as arrows. Assemble the lower pulling bar (13) or the ankle strap (58) to the end of the cable (52A) by the chain (30) and the hook (25).

Step 9

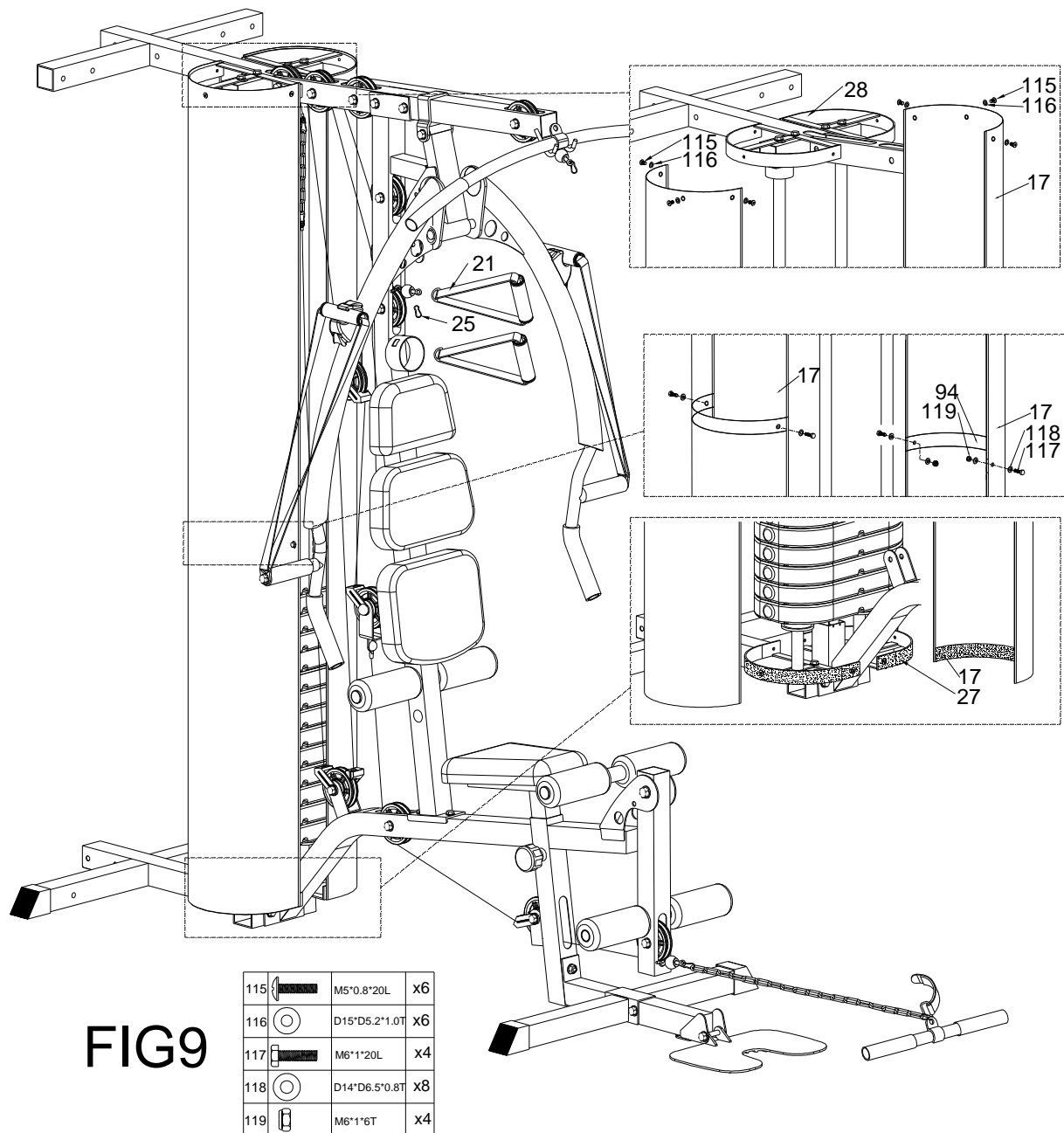

FIG9

- 1) Assemble the curved plate (94) to the weight protector (17) by the bolt (117), the flat washer (118) and the nylon nut (119).
- 2) Assemble the weight protector (17) to the lower weight protector support (27) and the upper weight protector support (28) by the bolt (115) and the flat washer (116).

Step 10

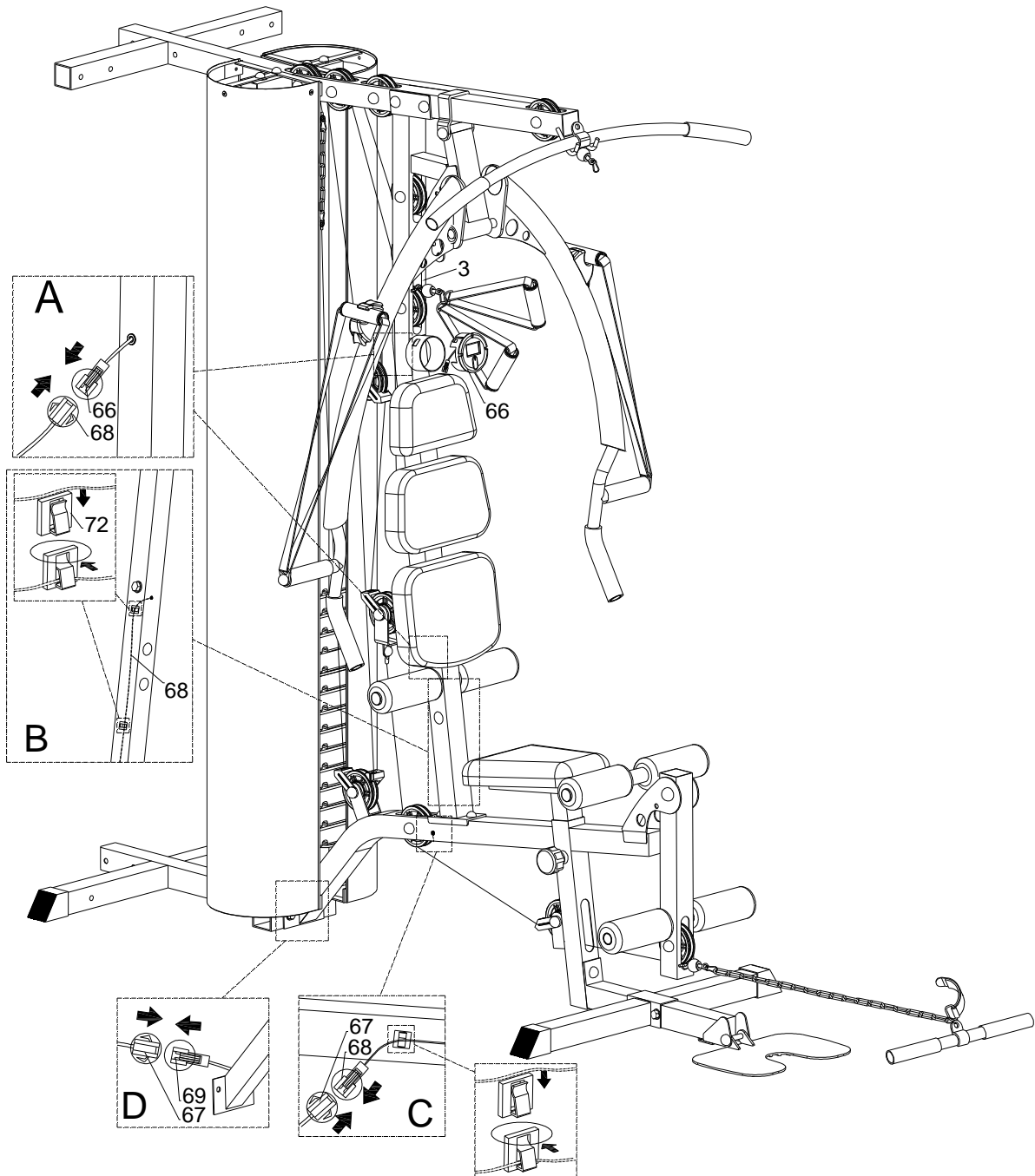

FIG10

- 1) Assemble the computer (66) to the front vertical support (3).
- 2) Connect the cable that is pre-assembled to the computer (66) with the middle computer cable (68) shown as fig. A.
- 3) Fix the middle computer cable (68) by the nip for computer cable (72) shown as fig. B.
- 4) Connect the upper computer cable (67) with the middle computer cable (68) shown as fig. C.
- 5) Connect the upper computer cable (67) with the lower computer cable (69) shown as fig. D.

Step 11

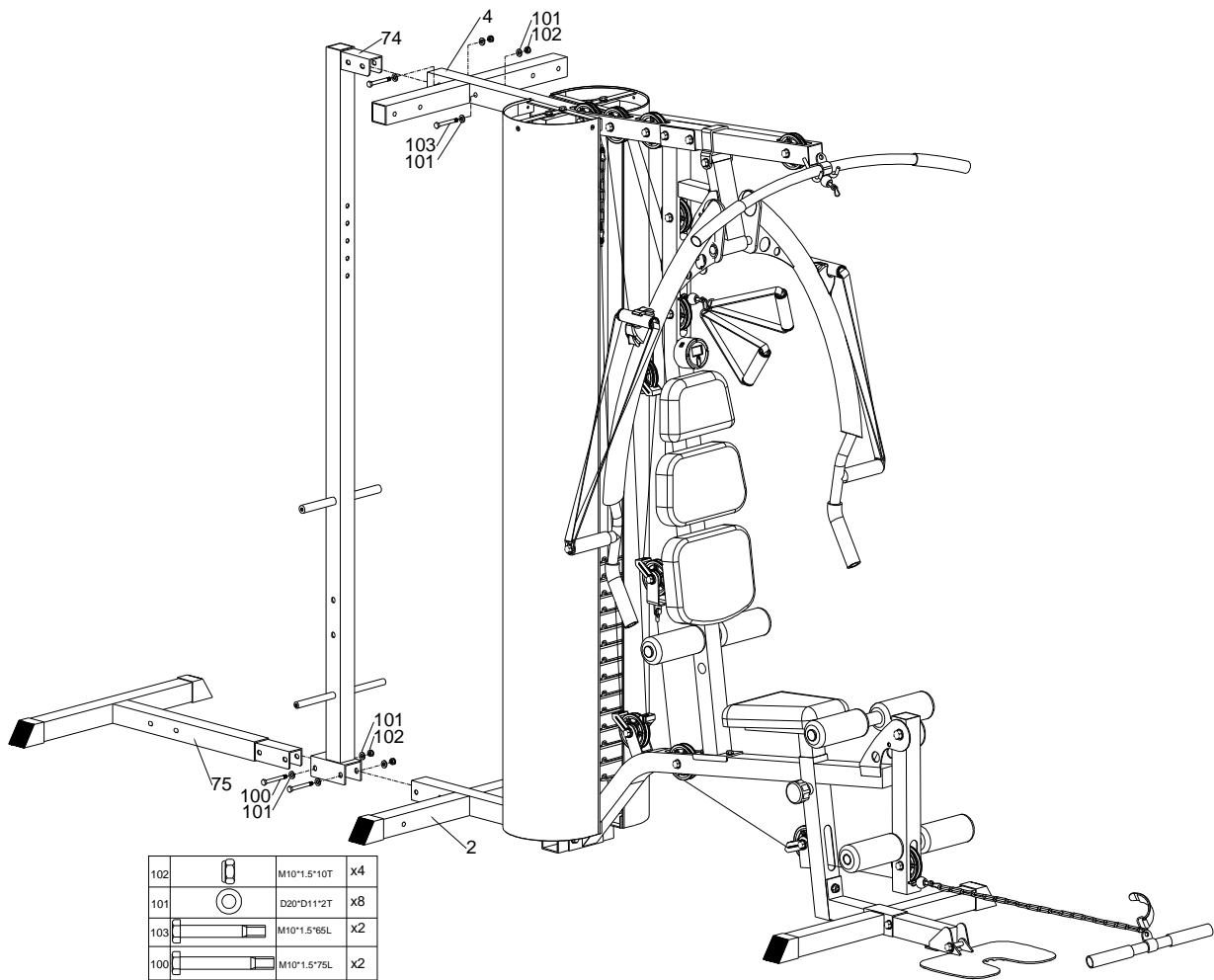

FIG11

- 1) Assemble the rear vertical support (74) to the top frame (4) by the flat washer (101), the nylon nut (102) and the bolt (103).
- 2) Assemble the rear floor frame (75) to the middle floor frame (2) and the rear vertical support (74) by the flat washer (101), the bolt (100) and the nylon nut (102).

Step 12

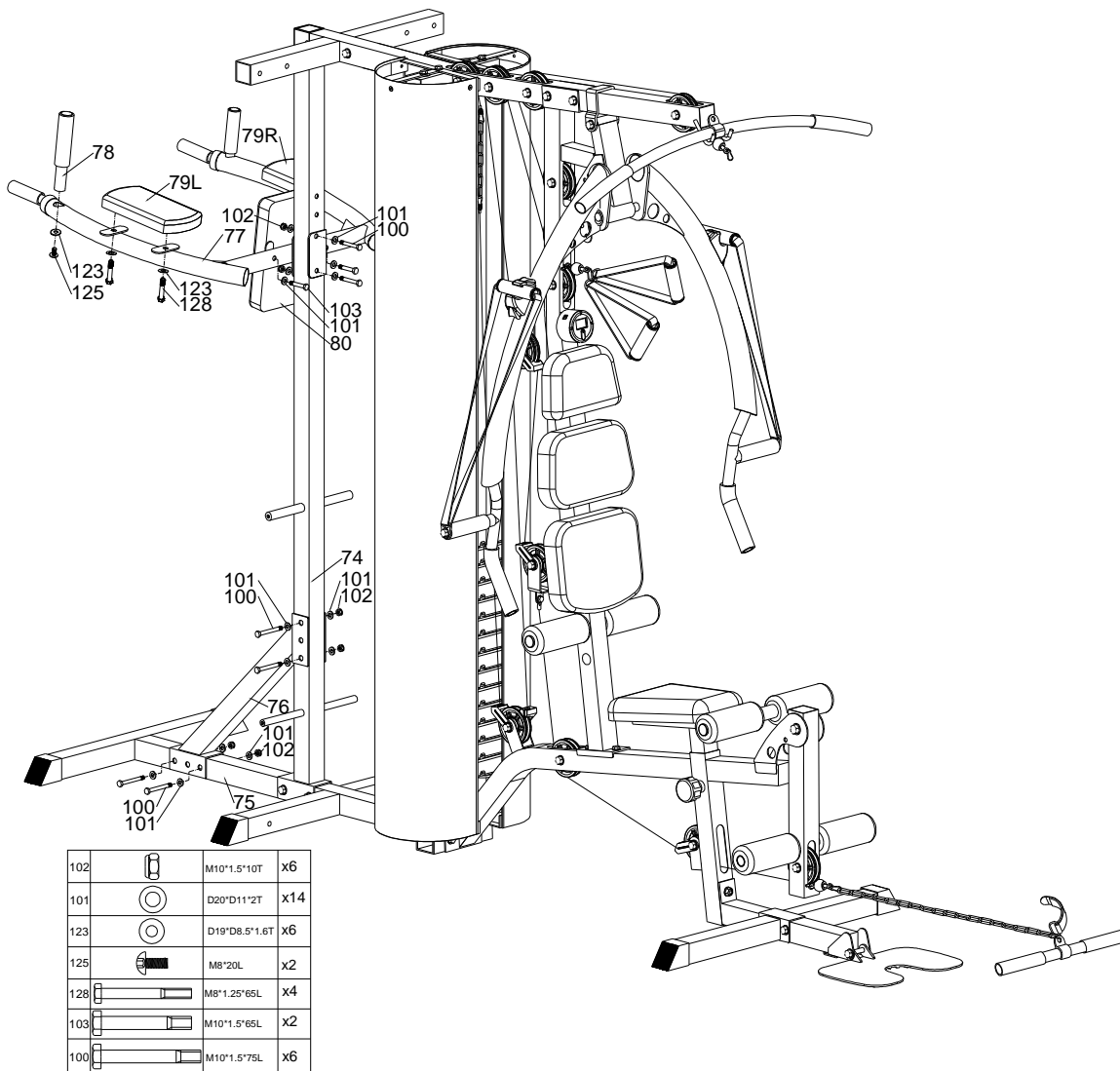

FIG12

- 1) Assemble the arm pad support (77) to the rear vertical support (74) by the bolt (100), the flat washer (101) and the nylon nut (102).
- 2) Assemble the backrest (80) to the arm pad support (77) by the flat washer (101) and the bolt (103).
- 3) Assemble the left arm pad (79L) and the right arm pad (79R) to the arm pad support (77) by the flat washer (123) and the bolt (128).
- 4) Assemble the handlebar (78) to the arm pad support (77) by the flat washer (123) and the bolt (125).
- 5) Assemble the rear incline support (76) to the rear vertical support (74), and to the rear floor frame (75) by the bolt (100), the flat washer (101) and the nylon nut (102).

Step 13

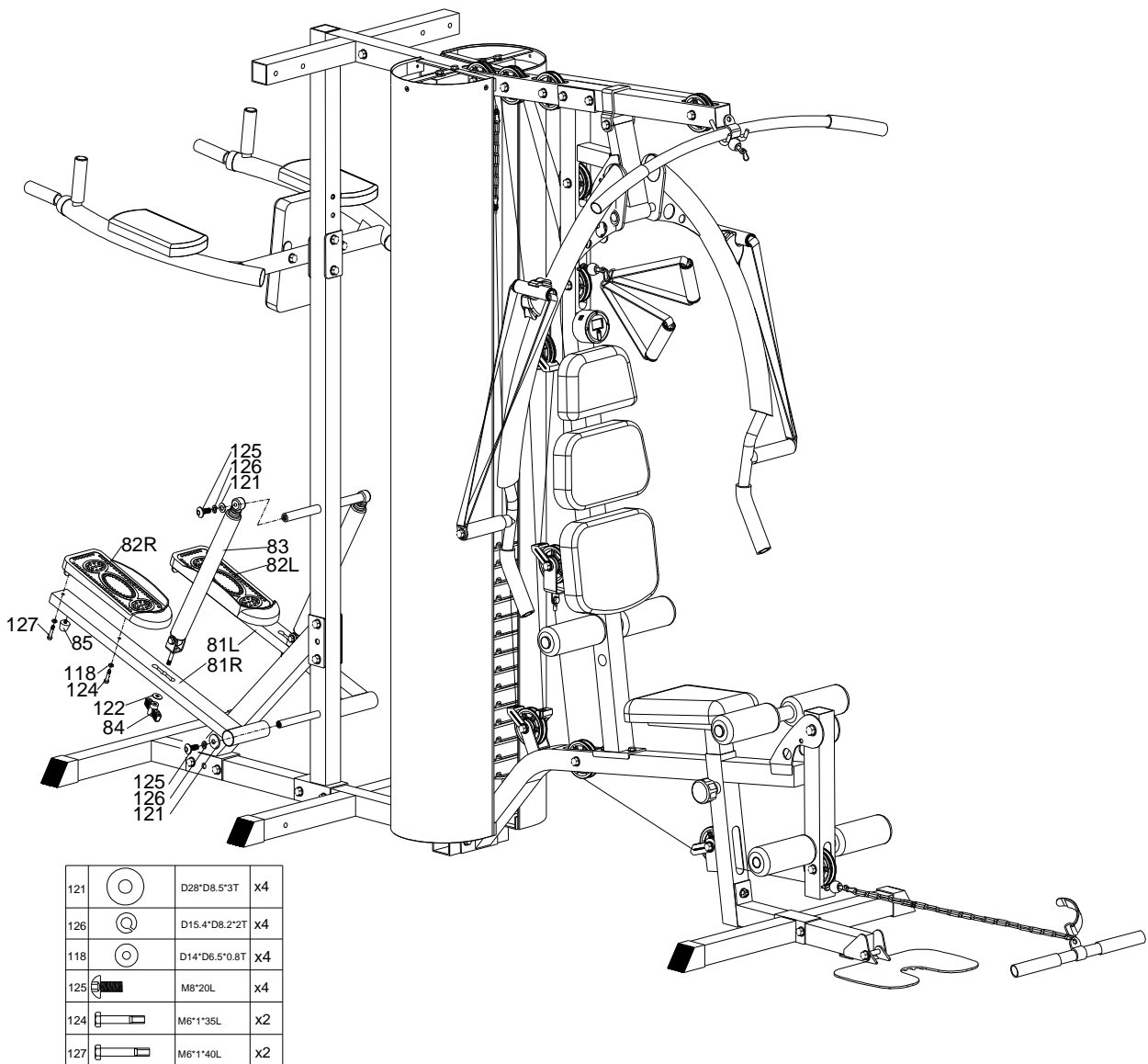

FIG13

- 1) Assemble the left pedal support (81L) and the right pedal support (81R) to the rear vertical support (74) by the flat washer (121), the bolt (125) and the spring washer (126).
- 2) Assemble the Hydraulic cylinder (83) to the rear vertical support (74) by the flat washer (121), the bolt (125) and the spring washer (126). Assemble the Hydraulic cylinder (83) to the left pedal support (81L) and the right pedal support (81R) by the T-shape knob (84) and the flat washer (122).
- 3) Assemble the left pedal (82L) and the right pedal (82R) to the pedal support (81L&81R) by the flat washer (118), the bolt (124) and the bolt (127).
- 4) Assemble the buffer (85) to the pedal support (81L&81R).

Step 14

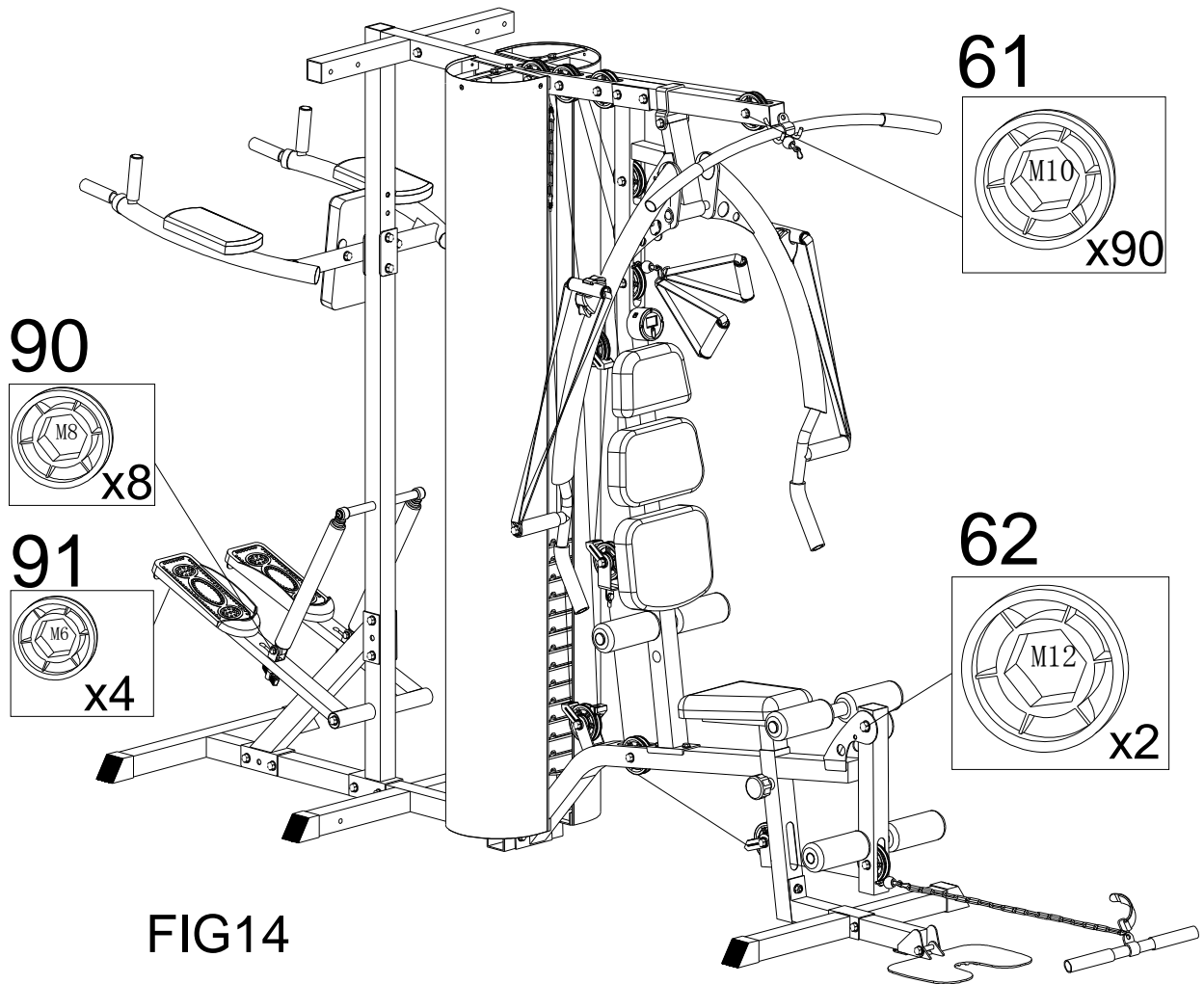
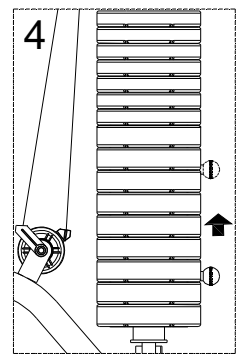
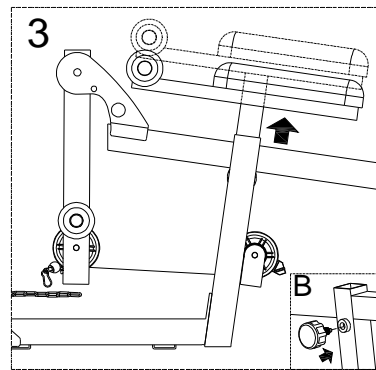
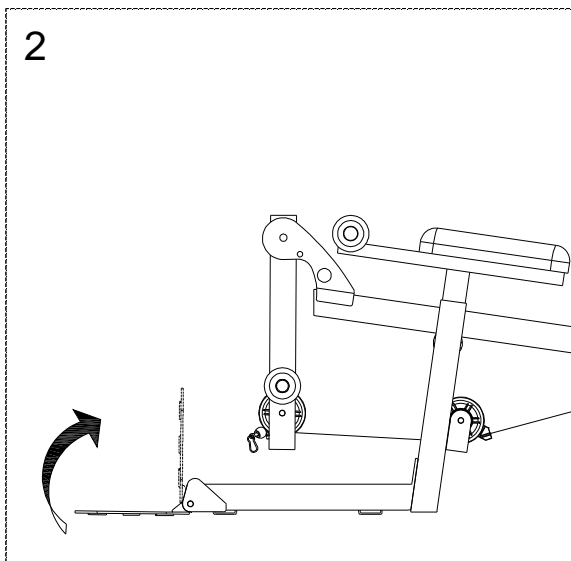
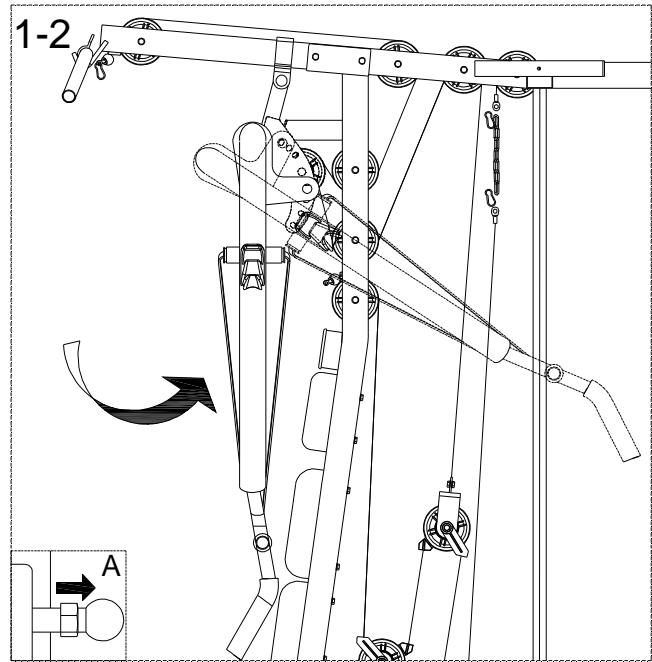
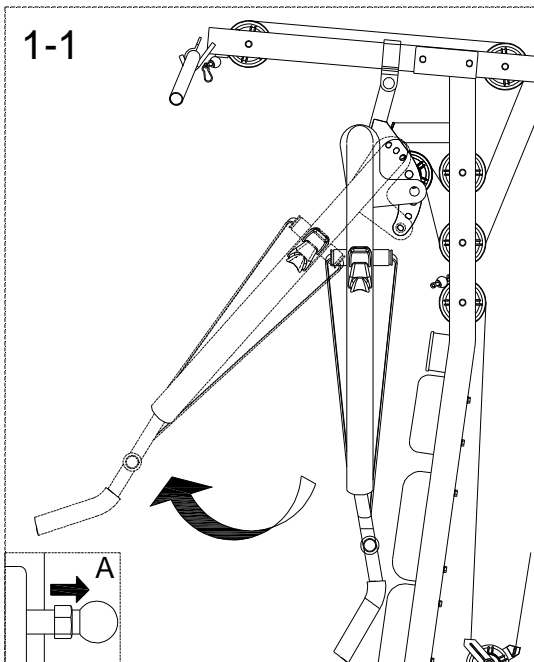

FIG14

Assemble the screw cap (61&62&90&91) to the screws.

Notes



- 1) Users could pull the butterfly arm forward and backward according to different target for exercise shown as fig. 1-1 and fig 1-2.
- 2) The plate for foot could be adjusted vertically shown as fig. 2.
- 3) The height of the seat could be adjusted by turning the knob shown as fig. B.
- 4) Users could select the quantity of the weight plates by the ball pin.

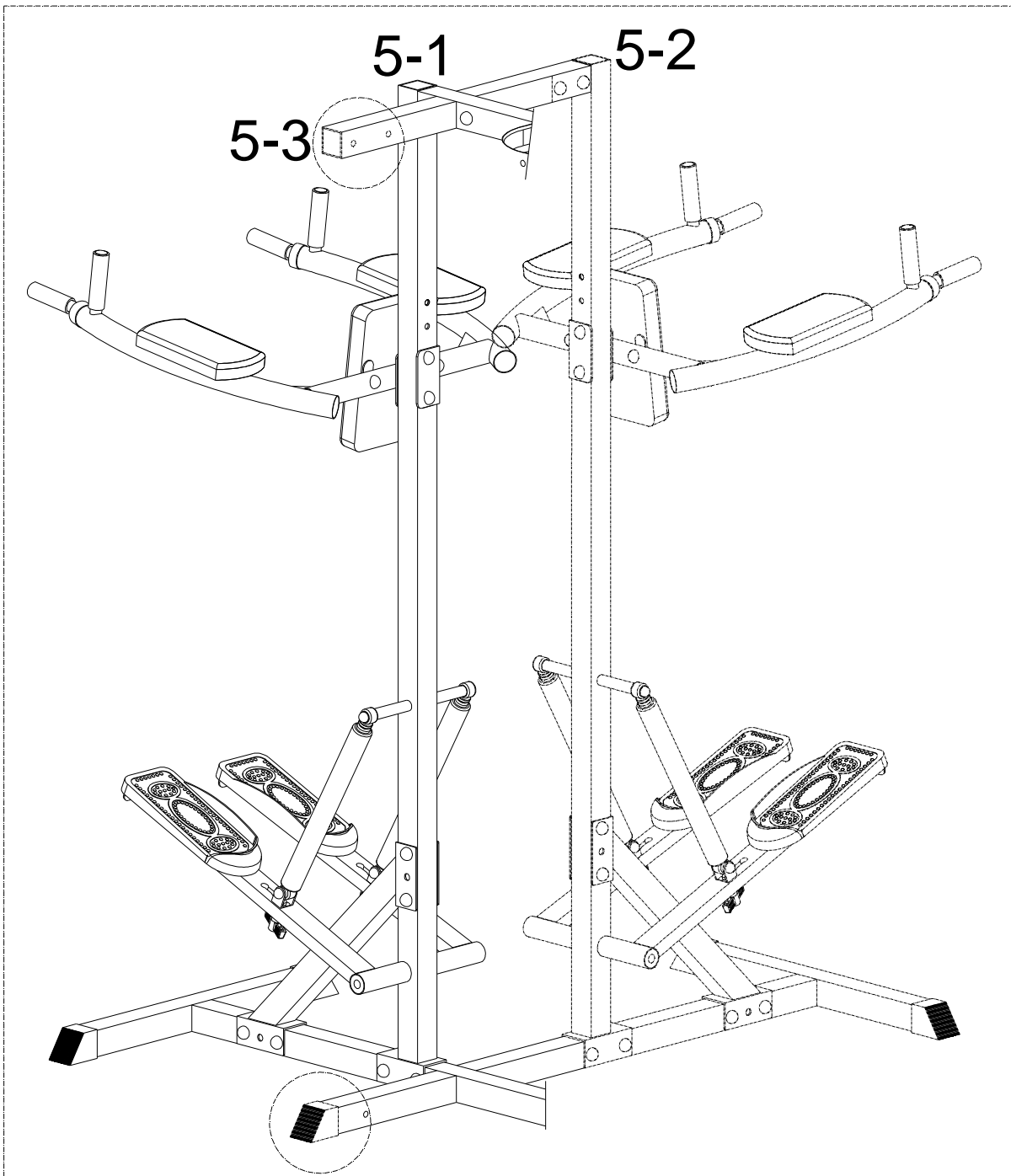

The VKR+STEPPER could be adjusted in different positions shown as fig. 5-1/2/3.

1. Back part of the item;
2. Left part of the item;
3. Right part of the item.

Computer instruction (BC-80258)

BATTERY ASSEMBLY

1. Take the computer that has been supplied out of the packaging and insert the battery <1.5V cell>according to the illustration on the back of the computer
2. Connect the computer and the unit with the cable as shown in the following drawing and then push the computer into the locator on the covering cap.
3. Ensure that the cable is not trapped

SPECIFICATIONS

TIME-----00:00—99.59
STRIDES/MIN-----15—3000RPM
COUNT-----0—9999
CALORIES-----0—9999

SCAN

KEY FUNCTION

MODE/SELECT

1. To select the function you want. Hold the key for 2 seconds to have all function values reset<total reset>.
2. To input the target value and also let the value reset.

OPERATION PROCEDURES

AUTO ON/OFF:

The monitor will be automatically shut off if there is no signal coming in for 256 seconds. The monitor will be auto-powered when start exercise or press the key.

FUNCTION

- <1>TIME-----Auto-memorize the workout time while exercising.
<2>STRIDES/MIN-----Display the steps per minute while exercising.
<3>COUNT----Accumulate the steps while exercising.
<4>CALORIE----Auto-memorize calories amount consumed while exercising.
<5>SCAN-----Automatically scan through each function between
1.TIME 2.COUNT 3.CALORIES 4.TTL COUNT 5.SCAN

OPERATION

1.(Windows=1) When battery is installed, LCD will display all graphics for 1 second, and following with 1 second BEEP. Console will go into FUNCTION TEST mode, by displaying wheel size (for 1 second), then display Cal value (for 1 second), then return to TIME FUNCTION.

2. (Windows=2) When battery is installed, LCD will display all graphics for 1 second, and then the console will go into TIME FUNCTION mode.

3. If idle more than 256 Seconds, console will automatically go into HALT stage. Any input signal or key in will release halt, and restore back to previous stage.

4. Press Mode key during exercise condition, enables selection of desired functions

3.1 Count function's displaying order as follow: (1 Windows)

TIME → COUNT → CALORIES → TTL COUN → SCAN

3.2 Count function's displaying order as follow: (2 Windows) RPM constantly displays, not included in the mode.

TIME → COUNT → CALORIES → TTL COUNT → SCAN

3.3 When press and hold this key for 2 seconds, it will reset all function values (except TTL Count), and return to default display.

3.4 If press and hold this key for 5 seconds, enters setting mode. Setting mode displays in following order: Time -> Count -> Calories -> Escape (out of setting mode)

TIME → COUNT → CALORIES