

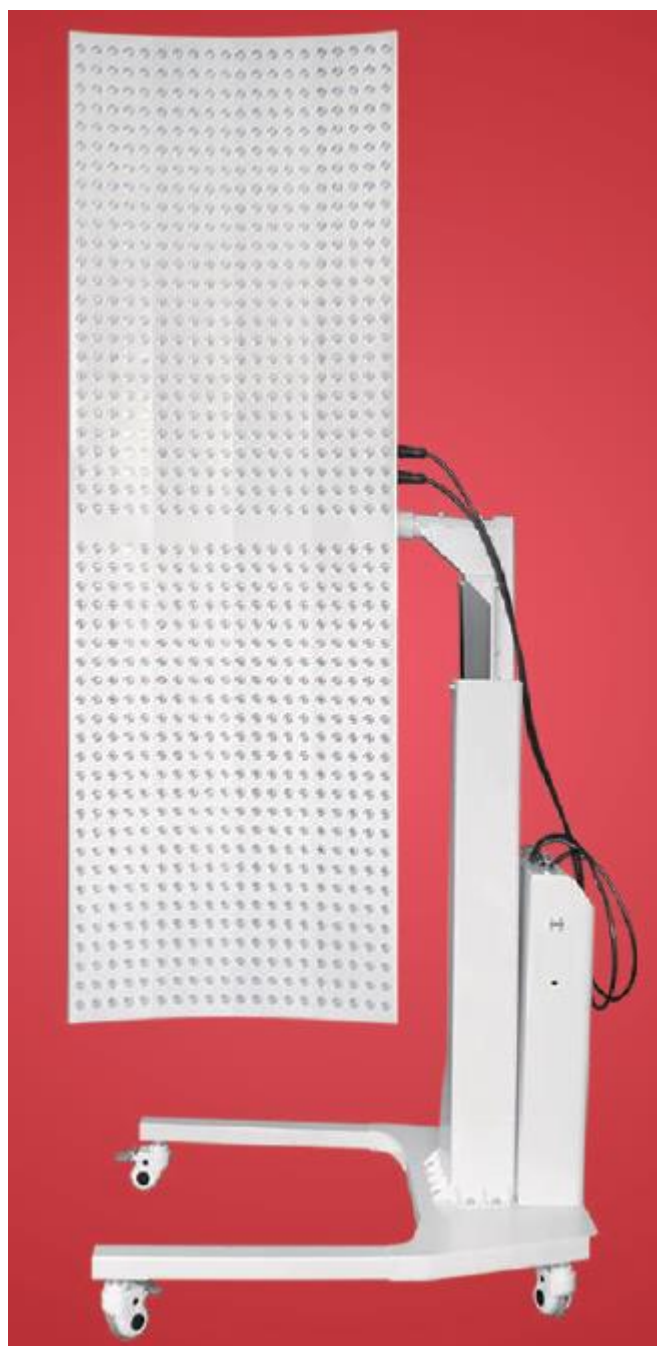

**USER MANUAL – EN**

**IN 25854 Infra LED panel inSPORTline Supetar**



# CONTENTS

- SAFETY INSTRUCTIONS..... 3
- USE ..... 3
- SPECIFICATIONS..... 4
- CLEANING AND MAINTENANCE ..... 5
- PARTS LIST ..... 5
- ASSEMBLY ..... 6
  - Step 1 ..... 6
  - Step 2..... 7
  - Step 3..... 8
  - Step 4..... 9
  - Step 5..... 9
  - Step 6..... 10
  - Step 7..... 10
  - Step 8..... 10
- ENVIRONMENT PROTECTION ..... 11
- TERMS AND CONDITIONS OF WARRANTY, WARRANTY CLAIMS..... 11

SevenSport s.r.o. reserves the right to make any changes and improvements to its product without prior notice. Visit our website [www.insportline.eu](http://www.insportline.eu) where you will find the latest version of the manual.



## SAFETY INSTRUCTIONS

- Read the manual carefully before first use and assembly and keep it for future reference.
- The device is not a toy, do not leave children and pets near the device unattended.
- Do not look directly at the lights.
- The device must be mounted correctly, if you are not sure about the mounting, contact a specialist.
- The product is not suitable for: pregnant women, people suffering from epilepsy, allergies to light and heat, people suffering from sensitive skin, dermatological diseases, people with injuries or scars, etc.
- Do not immerse in water.
- Do not use for a long periods time.
- Do not modify or repair the device.
- Do not use sprays containing aerosols in the room.
- Do not use in rooms with high humidity.
- Keep away from open flames.
- Store away from heat sources.
- Frequency of use: initially 1-2 min per area, over 2-3 weeks up to 10 min per area.
- Standard use can be 10 minutes per session at 15 to 40 cm from the device. The maximum time of use can be 15-20 min for problem areas. We recommend keeping 6-hour intervals between sessions and using the device 2-3 times a day.

**WARNING:** The device is not a substitute for medical or therapeutic care.

**WARNING:** Wear eye protection. Never look directly into LEDs. NIR (Near Infrared Light) is not visible to the naked eye.

## USE

Place the LED panel above the therapy bed and secure with the brakes on the wheels.	
Unlock the door on the side of the electrical box and use the buttons to adjust the height of the panel.	
Start the panel and hold the "T" button to set the time.	

Use the knob to adjust the brightness in levels L1 - L9.



Adjust the red or NIR radiation (660 / 850 mode) depending on whether you want to irradiate the skin or deep tissues.



1. Switch, timer, mode

5. Setting the intensity

2. Lock

6. Up

3. Output

7. Pause

4. Emergency button

8. Down

## SPECIFICATIONS

Panel size	190 x 64 x 11 cm
Weight	Stand: 58.85 kg, Panel: 34.65 kg
Input voltage	100-240 V, 50/60 Hz
Spectrum	660 nm, 850 nm
Number of LEDs	1000 pcs, 3W (480 pcs 660 nm, 520 pcs 850 nm)
Material	Metal
Certificate	CE, FDA, RoHS
Package contents	1x LED panel, 1x power cable, 1x glasses, 1x manual, 1x controller









## CLEANING AND MAINTENANCE

Before cleaning, make sure that the device is disconnected from the current. Clean the metal parts (except the LED lights) with a damp micro-thin cloth. Never apply water directly to the device. Do not allow water or moisture to enter the vents.

Do not use aggressive cleaning agents.

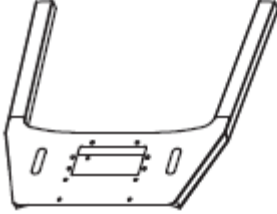
Store in a shady, dry and clean place at temperatures from 0 - 40°C

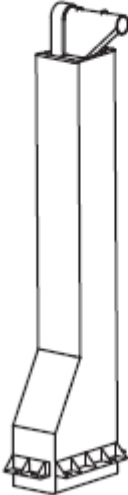
## PARTS LIST

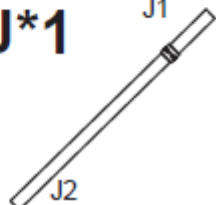
<p><b>A*3</b></p>  <p>M8*65MM</p>	<p><b>B*13</b></p>  <p>M8*12MM</p>	<p><b>C*2</b></p>  <p>M8*15MM</p>	<p><b>D*1</b></p>  <p>M8*130MM</p>
<p><b>E*1</b></p> 	<p><b>G*1</b></p> 	<p><b>H*1</b></p> 	
<p><b>F*1</b></p> 		<p><b>I*4</b></p> 	
<p><b>J*1</b></p> 			

# ASSEMBLY

## Step 1

Attach the 4x wheels (I) to the base (E). Do not forget to press the brake on the wheels so that the base does not move. Attach the post (F) to the base (F) using 4x screws (B) on the bottom and 6x screws (B) on the top.

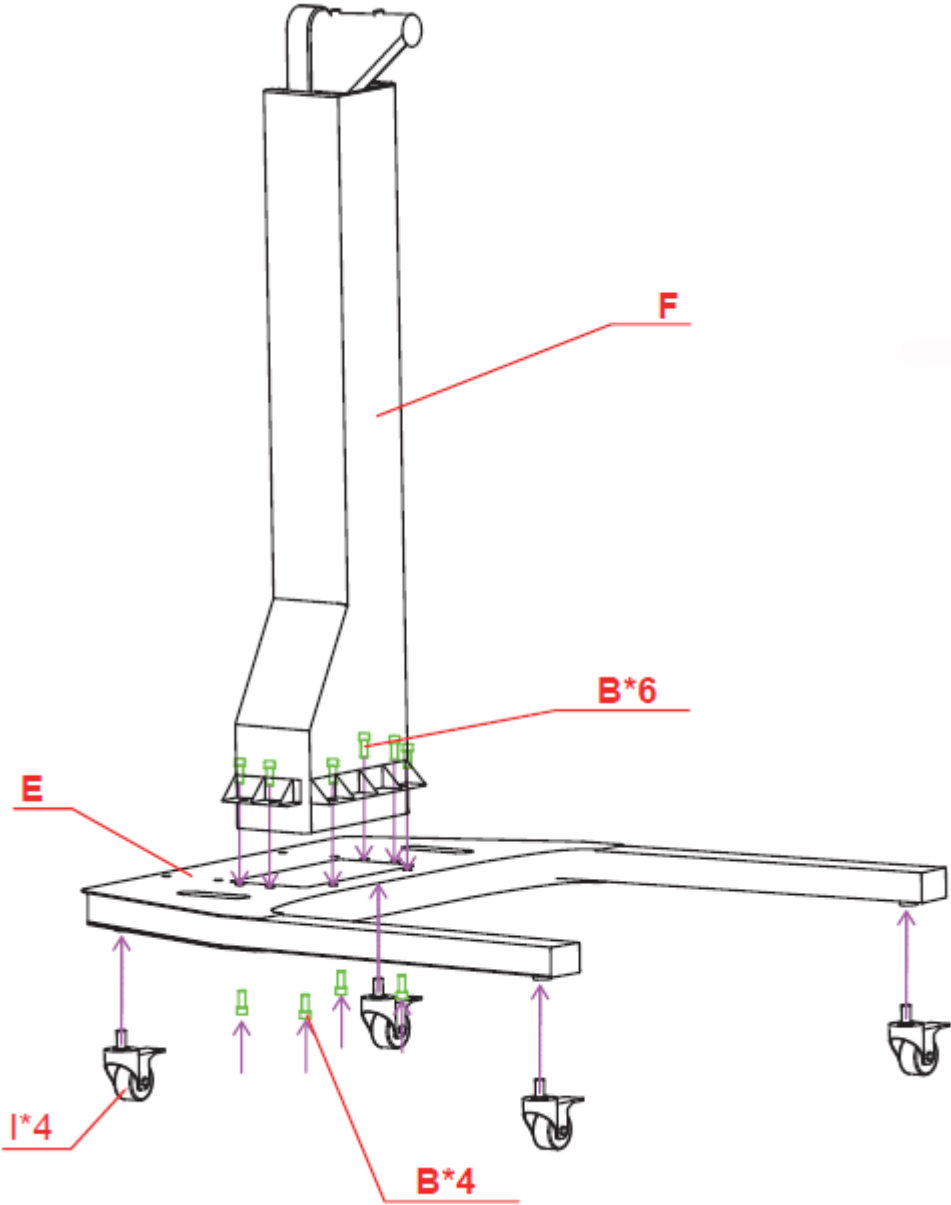

**Step 2**

Attach the electrical box (G) to the back of the base and post. Connect the cables leading from the electrical box (H) and the post (F). Secure the cables together and store in the electrical box.

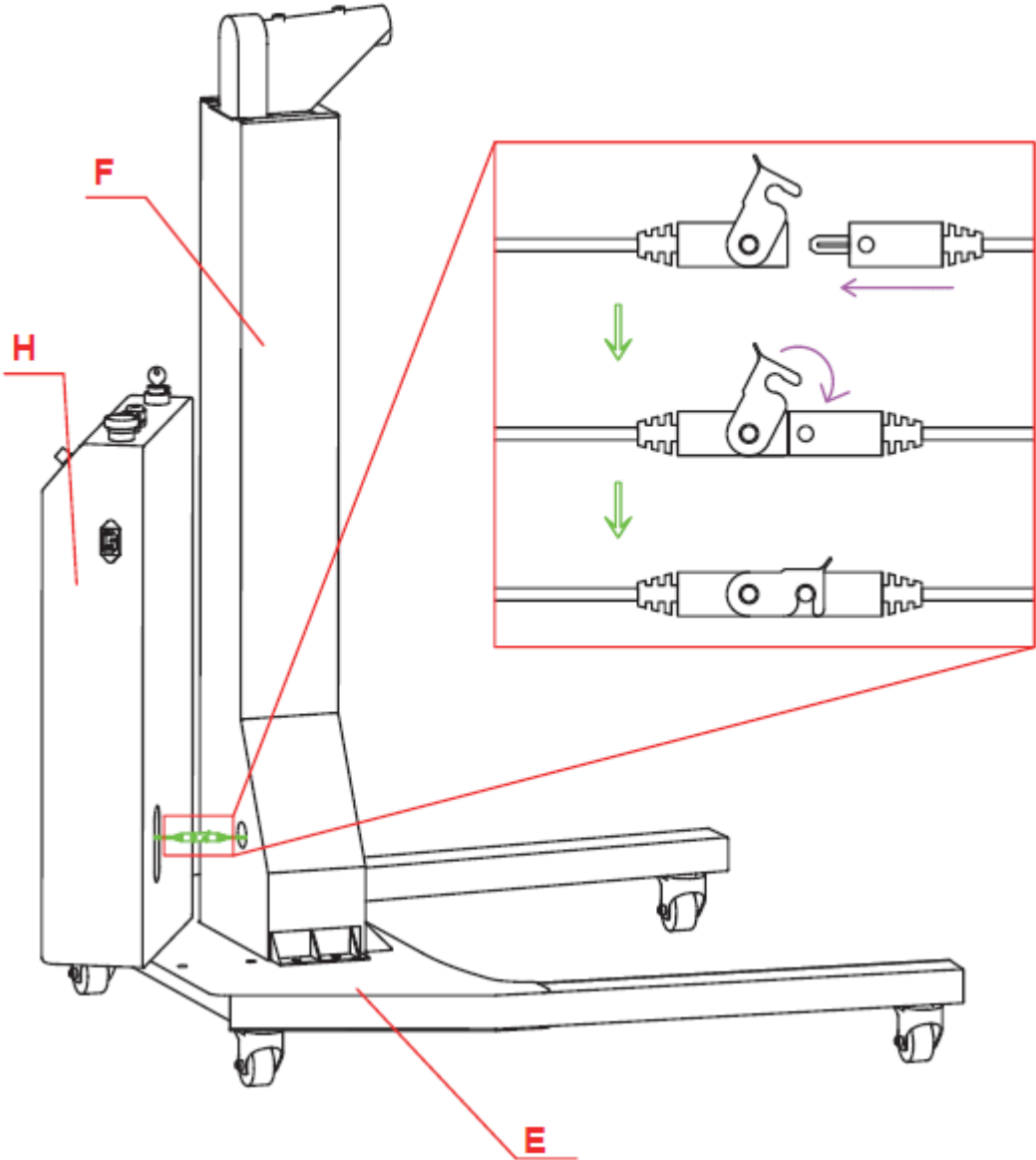

**Step 3**

Attach the electrical box (H) to the base (E) using 2x screws (A) and 2x screws (B).

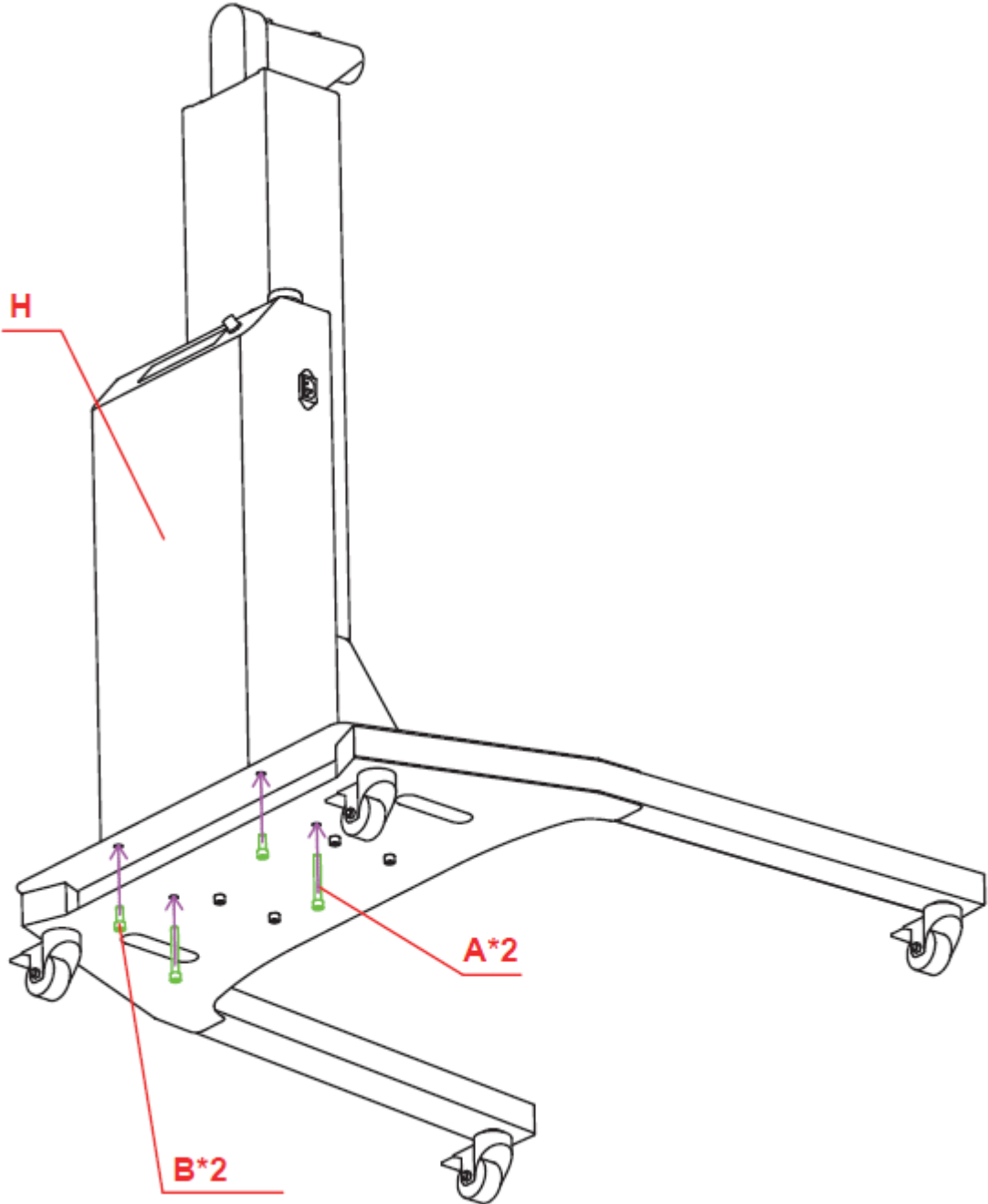



**Step 4**

Attach the support bar (J) to the post (F). Insert the support bar part (J1) into the column (F) and then secure with the screws (A and B).

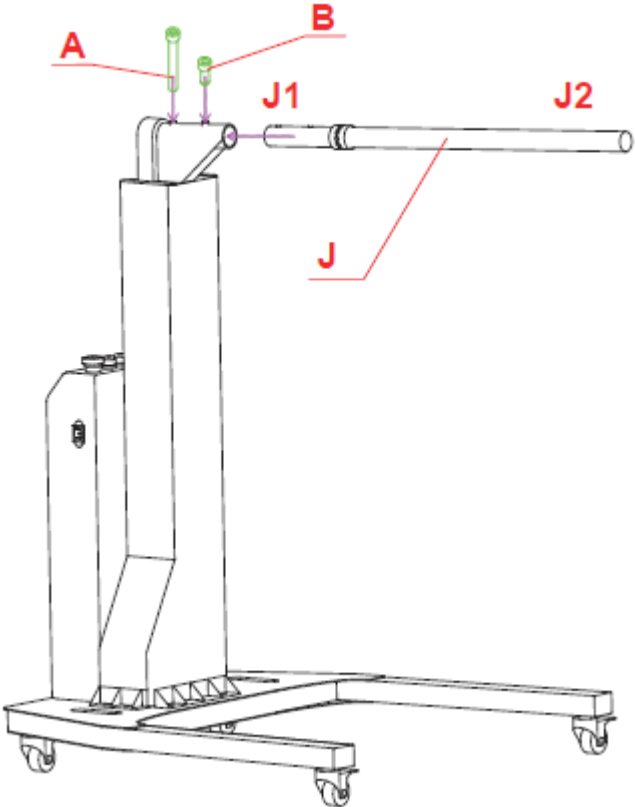

**Step 5**

Slide the panel (G) onto the support bar (J) as shown.

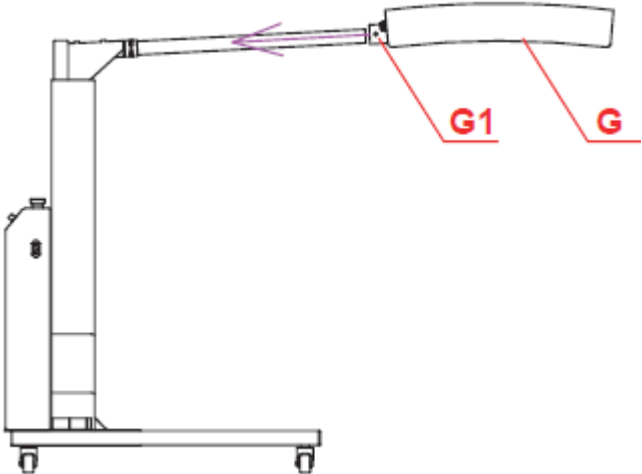

## Step 6

Use 2x screws (C) to connect the support bar (J) and the panel (G).

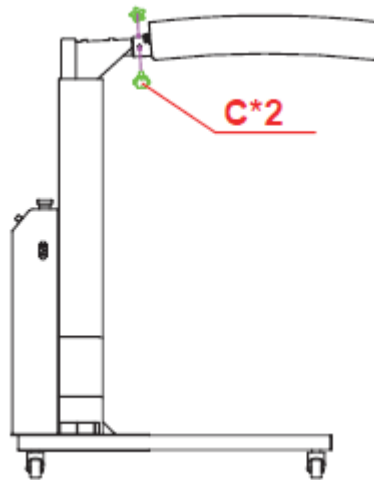

## Step 7

Connect the cables leading from the electrical box. Pay attention to the number of pins, one cable is 4-pin and one cable is 6-pin.

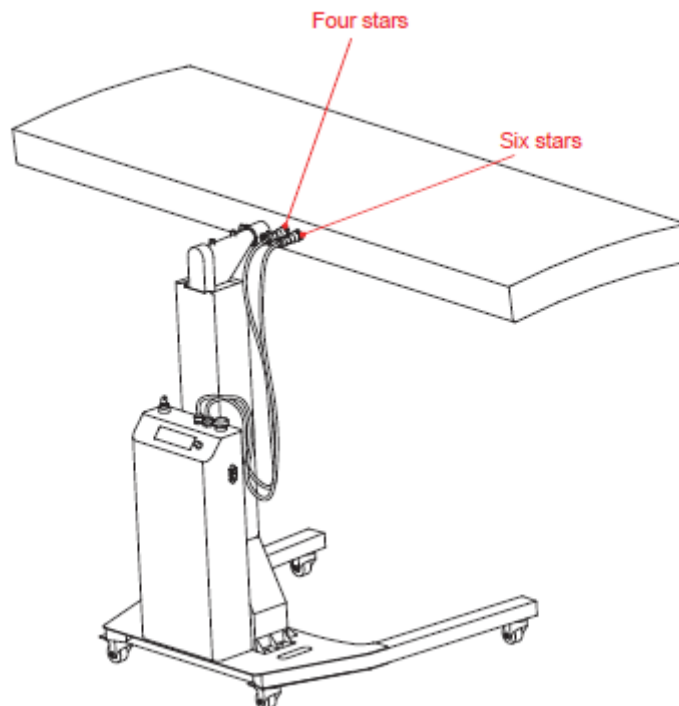

## Step 8

Plug in and turn on.

## ENVIRONMENT PROTECTION

After the product lifespan expired or if the possible repairing is uneconomic, dispose it according to the local laws and environmentally friendly in the nearest scrapyards.

By proper disposal you will protect the environment and natural sources. Moreover, you can help protect human health. If you are not sure in correct disposing, ask local authorities to avoid law violation or sanctions.

Don't put the batteries among house waste but hand them in to the recycling place.

## TERMS AND CONDITIONS OF WARRANTY, WARRANTY CLAIMS

### General Conditions of Warranty and Definition of Terms

All Warranty Conditions stated here under determine Warranty Coverage and Warranty Claim Procedure. Conditions of Warranty and Warranty Claims are governed by Act No. 89/2012 Coll. Civil Code, and Act No. 634/1992 Coll., Consumer Protection, as amended, also in cases that are not specified by these Warranty rules.

The seller is SEVEN SPORT s.r.o. with its registered office in Strakonická street 1151/2c, Prague 150 00, Company Registration Number: 26847264, registered in the Trade Register at Regional Court in Prague, Section C, Insert No. 116888.

According to valid legal regulations it depends whether the Buyer is the End Customer or not.

"The Buyer who is the End Customer" or simply the "End Customer" is the legal entity that does not conclude and execute the Contract in order to run or promote his own trade or business activities.

"The Buyer who is not the End Customer" is a Businessman that buys Goods or uses services for the purpose of using the Goods or services for his own business activities. The Buyer conforms to the General Purchase Agreement and business conditions.

These Conditions of Warranty and Warranty Claims are an integral part of every Purchase Agreement made between the Seller and the Buyer. All Warranty Conditions are valid and binding, unless otherwise specified in the Purchase Agreement, in the Amendment to this Contract or in another written agreement.

### Warranty Conditions

#### Warranty Period

The Seller provides the Buyer a 24 months Warranty for Goods Quality, unless otherwise specified in the Certificate of Warranty, Invoice, Bill of Delivery or other documents related to the Goods. The legal warranty period provided to the Consumer is not affected.

By the Warranty for Goods Quality, the Seller guarantees that the delivered Goods shall be, for a certain period of time, suitable for regular or contracted use, and that the Goods shall maintain its regular or contracted features.

#### The Warranty does not cover defects resulting from (if applicable):

- User's fault, i.e. product damage caused by unqualified repair work, improper assembly
- Improper maintenance
- Mechanical damages
- Regular use (e.g. wearing out of rubber and plastic parts, moving mechanisms, joints etc.)
- Unavoidable event, natural disaster
- Adjustments made by unqualified person
- Improper maintenance, improper placement, damages caused by low or high temperature, water, inappropriate pressure, shocks, intentional changes in design or construction etc.

### Warranty Claim Procedure

The Buyer is obliged to check the Goods delivered by the Seller immediately after taking the responsibility for the Goods and its damages, i.e. immediately after its delivery. The Buyer must check the Goods so that he discovers all the defects that can be discovered by such check.

When making a Warranty Claim the Buyer is obliged, on request of the Seller, to prove the purchase and validity of the claim by the Invoice or Bill of Delivery that includes the product's serial number, or eventually by the documents without the serial number. If the Buyer does not prove the validity of the Warranty Claim by these documents, the Seller has the right to reject the Warranty Claim.

If the Buyer gives notice of a defect that is not covered by the Warranty (e.g. in the case that the Warranty Conditions were not fulfilled or in the case of reporting the defect by mistake etc.), the Seller is eligible to require a compensation for all the costs arising from the repair. The cost shall be calculated according to the valid price list of services and transport costs.

If the Seller finds out (by testing) that the product is not damaged, the Warranty Claim is not accepted. The Seller reserves the right to claim a compensation for costs arising from the false Warranty Claim.

In case the Buyer makes a claim about the Goods that is legally covered by the Warranty provided by the Seller, the Seller shall fix the reported defects by means of repair or by the exchange of the damaged part or product for a new one. Based on the agreement of the Buyer, the Seller has the right to exchange the defected Goods for a fully compatible Goods of the same or better technical characteristics. The Seller is entitled to choose the form of the Warranty Claim Procedures described in this paragraph.

The Seller shall settle the Warranty Claim within 30 days after the delivery of the defective Goods, unless a longer period has been agreed upon. The day when the repaired or exchanged Goods is handed over to the Buyer is considered to be the day of the Warranty Claim settlement. When the Seller is not able to settle the Warranty Claim within the agreed period due to the specific nature of the Goods defect, he and the Buyer shall make an agreement about an alternative solution. In case such agreement is not made, the Seller is obliged to provide the Buyer with a financial compensation in the form of a refund.

**CZ**  
**SEVEN SPORT s.r.o.**

Registered Office: Strakonická 1151/2c, Praha 5, 150 00,  
ČR

Headquarters: Dělnická 957, Vítkov, 749 01  
Warranty & Service: Čermenská 486, Vítkov 749 01

CRN: 26847264  
VAT ID: CZ26847264

Phone: +420 556 300 970  
E-mail: eshop@insportline.cz  
reklamace@insportline.cz  
servis@insportline.cz

Web: www.inSPORTline.cz

**SK**  
**inSPORTline s.r.o.**

Headquarters, warranty & service center: Elektrická 6471,  
Trenčín 911 01, SK

CRN: 36311723  
VAT ID: SK2020177082

Phone: +421(0)326 526 701  
E-mail: objednavky@insportline.sk  
reklamacie@insportline.sk  
servis@insportline.sk

Web: www.inSPORTline.sk

**About shipping**

