

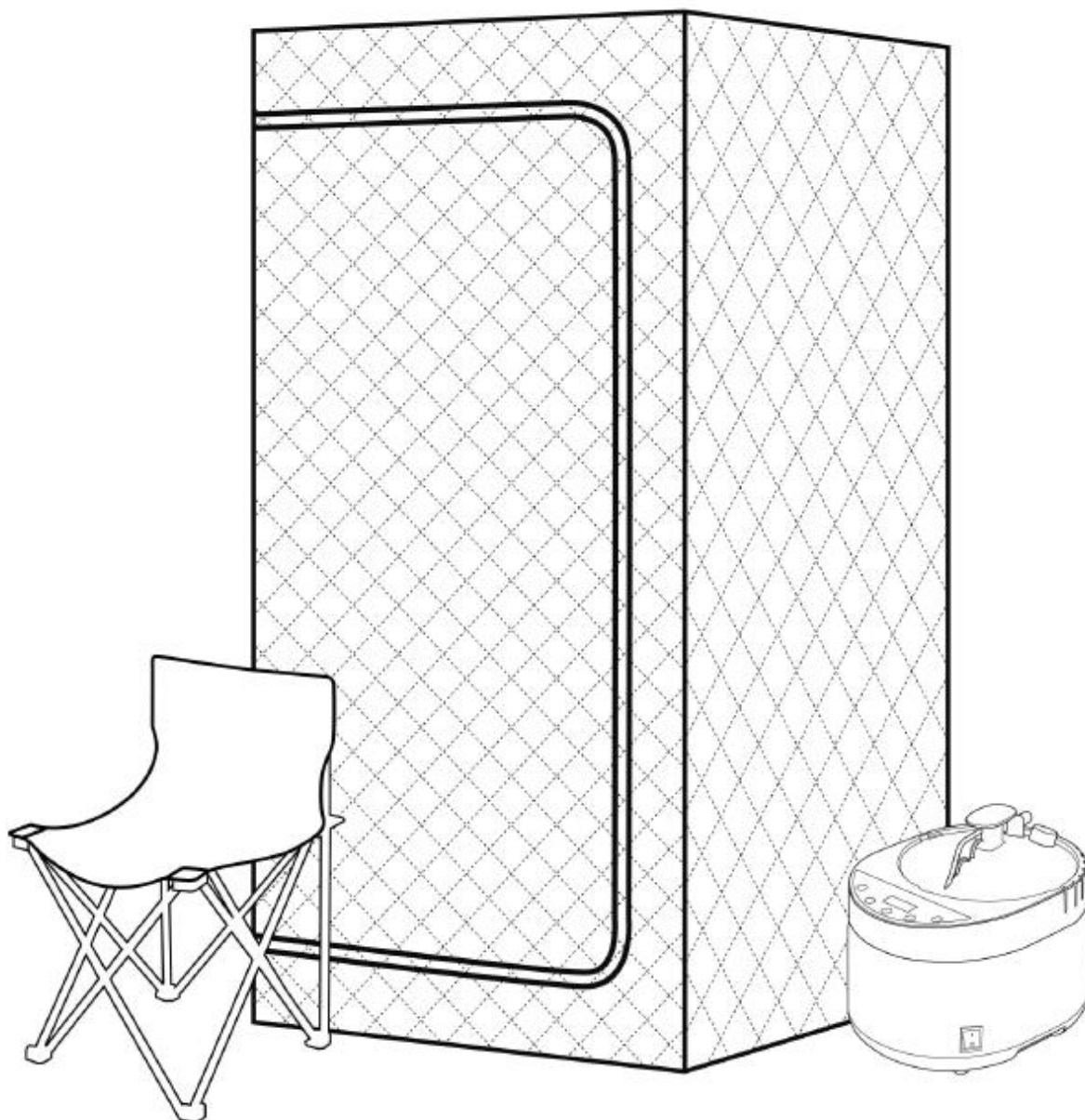

**USER MANUAL – EN**

**IN 25812 Portable steam sauna inSPORTline Laurenta**



**CONTENTS**

SAFETY INSTRUCTIONS..... 3  
PACKAGE ..... 3  
ASSEMBLY ..... 4  
USE ..... 6  
TECHNICAL SPECIFICATIONS ..... 8  
ENVIRONMENT PROTECTION ..... 8  
TERMS AND CONDITIONS OF WARRANTY, WARRANTY CLAIMS..... 8

## SAFETY INSTRUCTIONS

- Read the manual before use and keep it for future reference.
- Unplug the device after each use.
- Do not use in places with high humidity or near water.
- Keep the power cord away from heat sources.
- Do not use the device if the power cord or plug is damaged.
- Do not pull the power cord.
- Do not repair or modify the device.
- Any repairs must be performed by an authorized service center or your supplier.
- Keep the device away from sharp objects and edges.
- The product is not a toy, keep out of reach of children.
- Do not use continuously for more than 30 minutes and a maximum of 3 times a week.
- Do not use 24 hours after sunbathing or visiting a solarium.
- Maximum steam container volume 4 liters.
- Suitable for people over 18 years of age.

**WARNING:** The device is not a substitute for medical or therapeutic care.

**WARNING:** Consult a physician before use.

**WARNING:** Do not use the sauna if you suffer from: respiratory diseases or complications; heart disease; high or low blood pressure; pregnant women; dermatological diseases, after ingestion of drugs, alcohol or other addictive substances; for persons under 18 years of age.

## PACKAGE

- Sauna tent
- Foldable construction
- Folding chair
- 4L container for steam production + connecting hose
- Controller

# ASSEMBLY

Connect the frame of the structure as shown.

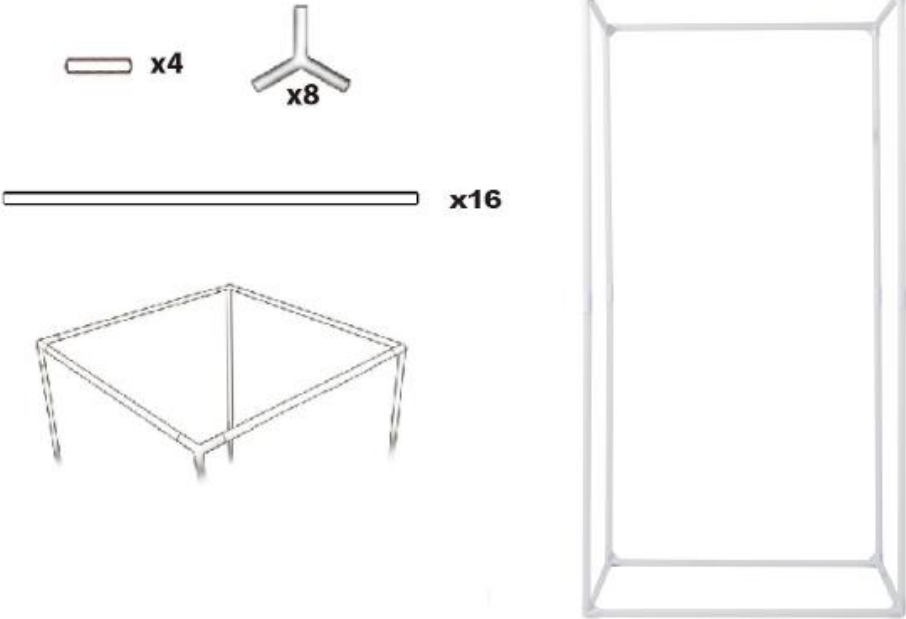

Unfold the tent and place the structure on the tent as shown.

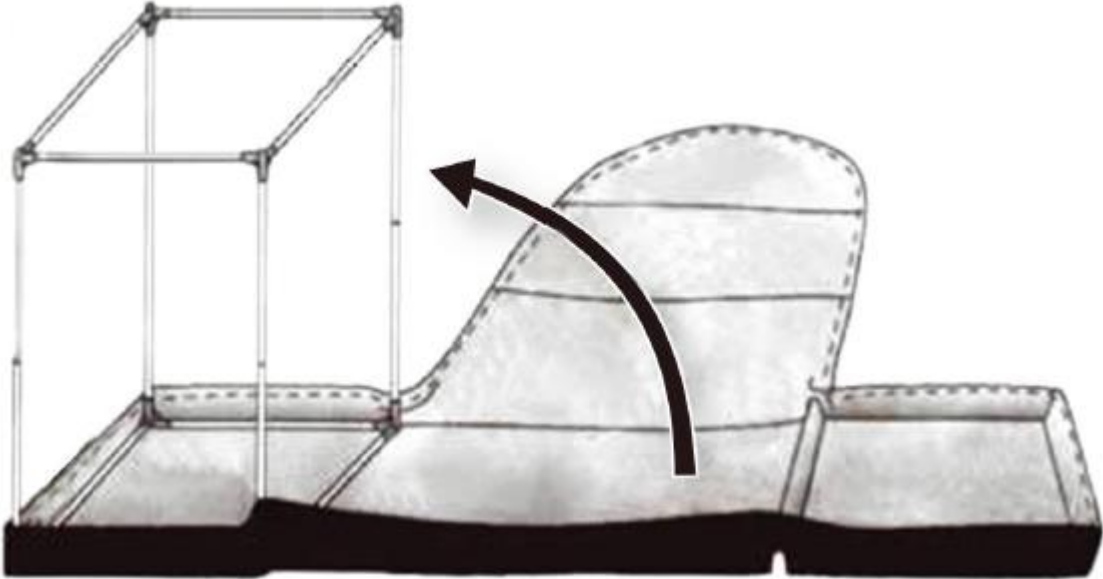



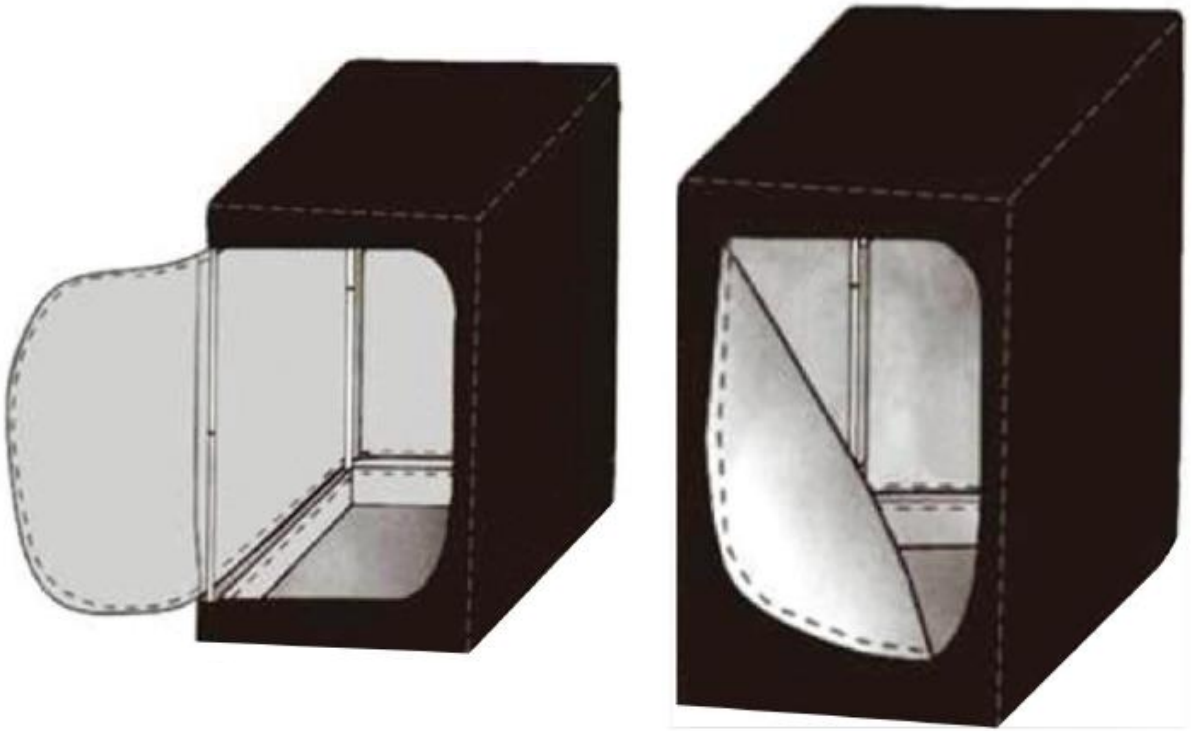

## USE

### Controller

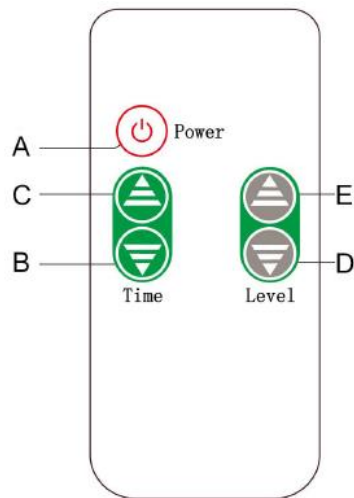

### Control panel

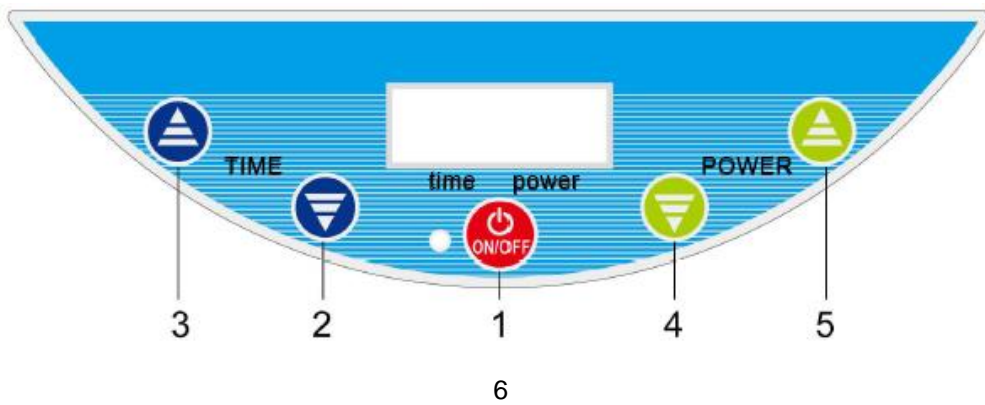

**Switch (1 / A)**

Press to turn the sauna on or off.

**Reduce time (2 / C)**

Press to reduce operating time.

**Increase time (3 / B)**

Press to increase the operating time.

**Reduce power (4 / D)**

Press to reduce power.

**Increase Power (5/E)**

Press to increase power.

Note: Always check the condition of the batteries in the controller.



**Step 1**

Turn on before use

**Step 2**

Attach the hose in the correct direction

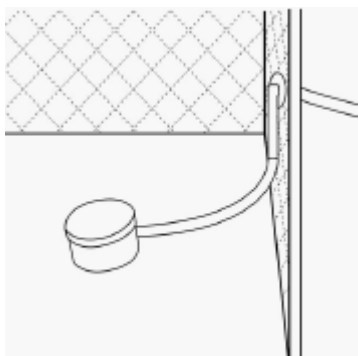
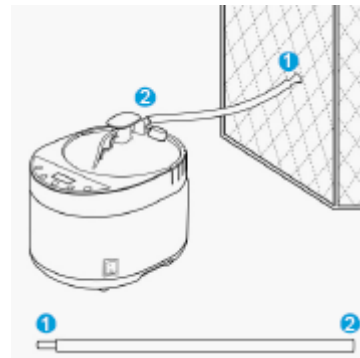

**Step 3**

Attach a container for herbs or essential oils.

#### Step 4

Add water, maximum 4 liters. Do not exceed the maximum marked volume.

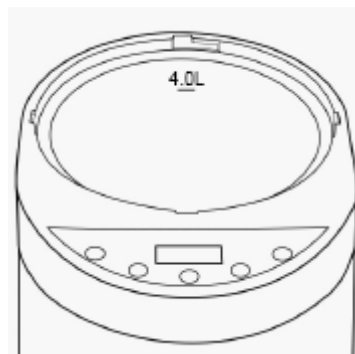

## TECHNICAL SPECIFICATIONS

Power	1500 watts
Maximum temperature	50 °C
Adjustable time	Up to 99 minutes
Levels	16 levels
Power supply	230 V
Dimensions	length 90 x width 90 x height 180 cm

## ENVIRONMENT PROTECTION

After the product lifespan expired or if the possible repairing is uneconomic, dispose it according to the local laws and environmentally friendly in the nearest scrapyard.

By proper disposal you will protect the environment and natural sources. Moreover, you can help protect human health. If you are not sure in correct disposing, ask local authorities to avoid law violation or sanctions.

Don't put the batteries among house waste but hand them in to the recycling place.

## TERMS AND CONDITIONS OF WARRANTY, WARRANTY CLAIMS

### General Conditions of Warranty and Definition of Terms

All Warranty Conditions stated here under determine Warranty Coverage and Warranty Claim Procedure. Conditions of Warranty and Warranty Claims are governed by Act No. 89/2012 Coll. Civil Code, and Act No. 634/1992 Coll., Consumer Protection, as amended, also in cases that are not specified by these Warranty rules.

The seller is SEVEN SPORT s.r.o. with its registered office in Strakonická street 1151/2c, Prague 150 00, Company Registration Number: 26847264, registered in the Trade Register at Regional Court in Prague, Section C, Insert No. 116888.

According to valid legal regulations it depends whether the Buyer is the End Customer or not.

“The Buyer who is the End Customer” or simply the “End Customer” is the legal entity that does not conclude and execute the Contract in order to run or promote his own trade or business activities.

“The Buyer who is not the End Customer” is a Businessman that buys Goods or uses services for the purpose of using the Goods or services for his own business activities. The Buyer conforms to the General Purchase Agreement and business conditions.

These Conditions of Warranty and Warranty Claims are an integral part of every Purchase Agreement made between the Seller and the Buyer. All Warranty Conditions are valid and binding, unless otherwise specified in the Purchase Agreement, in the Amendment to this Contract or in another written agreement.



## **Warranty Conditions**

### **Warranty Period**

The Seller provides the Buyer a 24 months Warranty for Goods Quality, unless otherwise specified in the Certificate of Warranty, Invoice, Bill of Delivery or other documents related to the Goods. The legal warranty period provided to the Consumer is not affected.

By the Warranty for Goods Quality, the Seller guarantees that the delivered Goods shall be, for a certain period of time, suitable for regular or contracted use, and that the Goods shall maintain its regular or contracted features.

### **The Warranty does not cover defects resulting from (if applicable):**

- User's fault, i.e. product damage caused by unqualified repair work, improper assembly, insufficient insertion of seat post into frame, insufficient tightening of pedals and cranks
- Improper maintenance
- Mechanical damages
- Regular use (e.g. wearing out of rubber and plastic parts, moving mechanisms, joints, wear of brake pads/blocks, chain, tires, cassette/multi wheel etc.)
- Unavoidable event, natural disaster
- Adjustments made by unqualified person
- Improper maintenance, improper placement, damages caused by low or high temperature, water, inappropriate pressure, shocks, intentional changes in design or construction etc.

### **Warranty Claim Procedure**

The Buyer is obliged to check the Goods delivered by the Seller immediately after taking the responsibility for the Goods and its damages, i.e. immediately after its delivery. The Buyer must check the Goods so that he discovers all the defects that can be discovered by such check.

When making a Warranty Claim the Buyer is obliged, on request of the Seller, to prove the purchase and validity of the claim by the Invoice or Bill of Delivery that includes the product's serial number, or eventually by the documents without the serial number. If the Buyer does not prove the validity of the Warranty Claim by these documents, the Seller has the right to reject the Warranty Claim.

If the Buyer gives notice of a defect that is not covered by the Warranty (e.g. in the case that the Warranty Conditions were not fulfilled or in the case of reporting the defect by mistake etc.), the Seller is eligible to require a compensation for all the costs arising from the repair. The cost shall be calculated according to the valid price list of services and transport costs.

If the Seller finds out (by testing) that the product is not damaged, the Warranty Claim is not accepted. The Seller reserves the right to claim a compensation for costs arising from the false Warranty Claim.

In case the Buyer makes a claim about the Goods that is legally covered by the Warranty provided by the Seller, the Seller shall fix the reported defects by means of repair or by the exchange of the damaged part or product for a new one. Based on the agreement of the Buyer, the Seller has the right to exchange the defected Goods for a fully compatible Goods of the same or better technical characteristics. The Seller is entitled to choose the form of the Warranty Claim Procedures described in this paragraph.

The Seller shall settle the Warranty Claim within 30 days after the delivery of the defective Goods, unless a longer period has been agreed upon. The day when the repaired or exchanged Goods is handed over to the Buyer is considered to be the day of the Warranty Claim settlement. When the Seller is not able to settle the Warranty Claim within the agreed period due to the specific nature of the Goods defect, he and the Buyer shall make an agreement about an alternative solution. In case such agreement is not made, the Seller is obliged to provide the Buyer with a financial compensation in the form of a refund.

Registered Office: Strakonická 1151/2c, Praha 5, 150 00, ČR  
Headquarters: Dělnická 957, Vítkov, 749 01  
Warranty & Service: Čermenská 486, Vítkov 749 01

CRN: 26847264  
VAT ID: CZ26847264

Phone: +420 556 300 970  
E-mail: eshop@insportline.cz  
reklamace@insportline.cz  
servis@insportline.cz

Web: www.inSPORTline.cz

**SK**  
**inSPORTline s.r.o.**

Headquarters, warranty & service center: Električná 6471, Trenčín 911 01, SK

CRN: 36311723  
VAT ID: SK2020177082

Phone: +421(0)326 526 701  
E-mail: objednavky@insportline.sk  
reklamacie@insportline.sk  
servis@insportline.sk

Web: www.inSPORTline.sk